

# GUIDELINES FOR DETERMINING PROCESS HEATING REQUIREMENTS

Often the requirement is simple: a heating element has performed to expectations but has finally failed due to exceeding its useful life-cycle. The catalog number is noted and consideration is given to ordering another one of the same.

In the continuous search for improvement, however, it has been determined that the next element should last longer. Analysis of the watt density, sheath material, and type of control indicates that the entire system needs to be redesigned. More heaters at a lower wattage each would reduce the watt density. The sheath should be upgraded to incoloy because of the presence of some corrosive materials. Electronic controls could replace the thermostats and the system zoned to improve process control.

But as the heater aged, so had the rest of the equipment. Maintenance costs and down-time were increasing. Product quality was not always what was expected. In addition, not enough material could be processed, cycle times were too long, and overall efficiency was not adequate. As the ultimate solution, the equipment was scrapped. New equipment could be designed to meet all current and future requirements. Specifications needed to include calculations for the amount of wattage necessary in addition to the factors described previously. The available electrical supply, operating environment, mechanical considerations, cost and efficiency also needed to be analyzed. The following method determined the new thermal system design:

## Description of System

### Calculation of Wattage Required

1. For Process Start-up
2. For Process Operation
3. To Replace Heat Losses
4. For Contingency Factors

### Determine Appropriate Watt Density

### Select Type of Heater(s)

### Determine Proper Sheath Material

### Thermal System Design

### Selection of Temperature Control

Assume those responsible for the introductory example successfully accomplished their task. Most materials can be effectively heated by conduction, convection or radiant energy produced by electric heaters. The information presented in the following pages contain the formulas, graphs, definitions, and other data necessary to apply **OGDEN** products in electric heating applications. The step-by-step method described is followed by detailed examples.

## DESCRIPTION OF SYSTEM

Determine what is to be achieved with a brief statement and a sketch.

## CALCULATION OF WATTAGE REQUIRED

### Considerations

1. Beginning and final temperatures
2. Time available to reach final temperature
3. Process cycle period
4. Weight and thermal properties of material being processed and of materials added during process cycle
5. Flow rates of liquids or gasses being heated
6. Dimensions, weights and thermal properties of containers, transfer medium, or anything else present that will absorb heat during the process

7. Surface area exposed to ambient where heat losses will occur

8. Effects and properties of insulation

Information for section 1, 2, 3, 5 and 7 is determined by the application requirements as per the Description statements.

Information for section 4, 6 and 8 is found in charts and graphs on the following pages.

See the **Thermal System Glossary** for definitions of the terms used.

Once the above information has been gathered, the formulas can be set-up and the calculations can begin.

$$Q_{ha} + Q_{ls} + CF = \text{kwh}$$

$$\frac{\text{kwh}}{\text{Hours allowed for process start-up}} = \text{kw}$$

where:

**Q<sub>ha</sub>** is the heat absorbed

**Q<sub>ls</sub>** are the heat losses through the system

**CF** is the contingency or safety factor

A. **Q<sub>ha</sub>:**

$$\frac{\text{weight (lbs.)} \times \text{specific heat (Btu/lb./}^\circ\text{F)} \times (\text{final—starting temperature})}{3412 \text{ Btu/kwh}} + \frac{\text{weight (lbs.)} \times \text{heat of fusion/vaporization (Btu/lb.)}}{3412 \text{ Btu/kwh}}$$

Both must be calculated for all material present in the system that will absorb heat.

B. **Q<sub>ls</sub>:**

$$\frac{\text{Exposed surface area (sq.ft.)} \times \text{Watts/sq.ft. loss at final temperature} \times \text{Hours allowed for start-up}}{1000 \text{ w/kw}} \times \frac{1}{2}$$

C. **CF:**

$$\%(\text{Q}_{ha} + \text{Q}_{ls})$$

10–35% kw additional for unknown or variable factors. 20% is common for most processes. In large thermal systems or in oven applications where the door is opened regularly, 30–35% is added.

$$\text{Wattage required for process start-up (kw)} = \frac{\text{A} + \text{B} + \text{C}}{\text{hours allowed for process start-up}}$$

## STEP 2: WATTAGE REQUIRED FOR PROCESS OPERATION

$$Q_{ha2} + Q_{ls2} + CF = \text{kw}$$

where:

**Q<sub>ha2</sub>** is the heat absorbed by new materials being processed

**Q<sub>ls2</sub>** are the heat losses through the system during processing

**CF** is the contingency or safety factor

D. **Q<sub>ha2</sub>:**

Apply same calculations as A for all new materials added to system during process operation (weight in lbs./hr.)

E. Qls2:

$$\frac{\text{Exposed surface area (sq.ft.)} \times \text{Watts/sq.ft. loss at final temperature}}{1000 \text{ w/kw}}$$

F. CF:

Apply same calculation as C.

**Wattage Required for Process Operation (kw) = D + E + F**

Generally, the greater of **step 1** or **step 2** will be the wattage installed. Often the requirement for start-up will be larger than for operation. Consider lengthening the start-up time to where **step 1** and **step 2** are nearly the same.

The **Heat of Fusion/Vaporization** calculation is required only if the material changes due to melting or evaporation. If the specific heat varies from one state to another, first calculate the kw requirement to the melting/vaporization point. Second, calculate the kw requirement for the heat of fusion or vaporization. Third, calculate the kw requirement to raise the molten or gaseous material to the final desired temperature. See Example 2.

In **step A** and **step D**, the calculations derived in the numerator are in Btu's. As the ratings of electric heaters are in watts or kilowatts, 3412 (the figure in the denominator) converts Btu's to kilowatts. One kilowatt hour is equal to 3412 Btu's.

If the material to be heated is a flowing liquid or gas, the information will be in gallons per minute for liquids (gpm); cubic feet per minute for air and gases (cfm). This must be converted to weight per hour, and will be determined by the density from chart 7T for liquids (lb./gal.) and by the combination of charts 8T and 9T for air and gasses (lb/cu.ft.). Because the density of a gas changes, air and gas processes also include velocity calculations. For heating forced air in ducts, only the Process Operation kw requirement is necessary. See Example 4. Then substituting:

**A. Qha or Qha2:**

$$\frac{\text{gpm or cfm} \times \frac{60 \text{ min.}}{\text{hr.}} \times \text{Density} \times \text{specific heat (final—starting)} \times \text{temperature}}{3412 \text{ Btu/kwh}}$$

In **step B** and **step E**, the calculations derived in the numerator are in watts. Dividing by 1000 converts watts to kilowatts. For process start-up, as shown in **step C**, an approximate averaging factor of 1/2 is utilized (heat losses will be 0 at start-up and increase to 100% as the temperature rises from beginning to final temperature). If the requirement for Process Start-Up is greater than two hours, multiply QIs by the approximate averaging factor of 2/3.

## DETERMINE APPROPRIATE WATT DENSITY

**Watt density** is the rated wattage of an element per unit of surface heated area (usually square inches), and indicates the potential to transmit heat. The formula is as follows:

$$\text{Watt Density} = \frac{\text{Rated Wattage}}{\text{Heated Surface Area}}$$

For example, a **Mighty Watt**, ½" x 12" (MWEJ12A0191) is rated 10000 watts. The standard cold section each end is ¾" per the specifications in the catalog section. The total cold area is ¾" making the heated length 11¼". Then:

$$\text{Watt Density} = \frac{\text{Rated Wattage}}{\text{Dia. x Heated Length x 3.14}}$$

$$\text{Watt Density} = \frac{1000}{.496 \times 11.25 \times 3.14}$$

$$\text{Watt Density} = 57 \text{ Watts/sq.in.}$$

As the definition indicates, the higher the watt density, the greater the possibility for excessive sheath temperatures. When designing the system, spreading the wattage requirement over more or larger heaters will reduce the operating watt density. Sheath temperatures will be reduced, increasing the heater's length of service. Note that every **OGDEN** heater has watt density and sheath temperature limitations shown in each catalog section.

Recommended allowable ratings for various materials, temperature conditions, and application considerations are also shown in the catalog sections and in the following pages. See Chart 23T. Certain materials such as water, vegetable oils, and metals have high conductivity rates. The heat generated travels quickly from the element and through the medium, allowing these materials to be heated at relatively high watt densities. Fuel oils, lubricating oils, hydraulic fluid, and other materials with low conductivity rates such as sugar syrups and most gasses must be heated at low watt densities. A major concern is to dissipate the heat generated by the element. If attention is not paid to guidelines for both the heater and the material being heated, watt densities too high will result in failure of the elements and possible damage to the material and equipment.

## SELECT TYPE OF HEATER(S)

The type of heater best suited for an application involves the dynamics of the process, space limitations, available electrical supply, cost, and appearance among other considerations. There could be several acceptable heaters for a single application. A water tank could be heated by direct immersion, clamped-on strip or tubular heaters, or even a band heater if the tank is cylindrical.

The following methods of installation are listed in the order of most effective transfer of heat from the element(s):

1. Immersed directly in liquids or gases
2. Inserted into drilled holes
3. Placed in milled slots or grooves
4. Mechanically clamped or wrapped around the surface
5. Spaced away, as a convective or radiant heat source

Most often the application will indicate the obvious selection.

Even though metal sheath heaters are quite durable, physical damage can occur. Protection, such as a shroud or guards might be necessary. In applying surface mounted heaters such as HD Strip Heaters or in some cases tubulars, intimate contact between the heater and the heated part is necessary to facilitate conductive heat transfer. This type of contact is also important in the installation of heaters in drilled holes and the strapping of band heaters to the mounting surface. Air gaps between the element and the heated part will result in higher sheath temperatures, and early failure.

Contamination can be said to be the leading cause of heater failure. Oils, plastics, vapors or other materials around the terminal areas will shorten heater life. Teflon, epoxy, ceramic-to-metal hermetic and other seals will often protect against contamination in some heater designs. Area atmospheric conditions may require complete terminal isolation from the environment by the use of NEMA IV or VII enclosures.

If lead wires are designed, continuous flexing or possible abrasion would call for armor cable or metal braided protection. Temperature and contaminants present also are deciding factors in the lead design and type chosen.

Further along in this section is a discussion on how the placement of heaters will improve heat distribution and heat patterns throughout a thermal system. At this point, the selection should emphasize what would be practical and efficient. Modifying the choice may become necessary in completing the design of the entire system.

## DETERMINE PROPER SHEATH MATERIAL

Information is located in each product section throughout the catalog in regards to the sheath materials available. In surface or air heating, operating at high temperatures can cause oxidation and scaling of the sheath. This impedes the transfer of heat from the element, resulting in over-heating and failure. It is always safe to specify Incoloy in these situations. The additional cost of the element will be recovered by providing longer service. In the direct heating of liquids and gasses, corrosion will be an important consideration in the selection of an immersion heater. An extensive Corrosion Resistance of Sheath Materials guideline (24T) is provided later in this section. Besides the information there, note the following:

- The effects of the solution concentration.
- As heat is a catalyst in a chemical reaction, lowering the watt density and in effect the sheath temperature will prolong the life of the element(s).
- Mineral deposits contained in a water supply can build-up on the elements, reducing the transfer of heat. Sheath temperatures can elevate to the point of failure. Stainless Steel or Incoloy sheath material will not attract the deposits as copper will and can operate at higher element temperatures should the build-up occur. This provides longer heater life.

In essence, the sheath material selected must be compatible with the process environment and the heat requirement.

Depending upon the design, many heaters have the potential to produce sheath temperatures exceeding 1400°F. This is where the heat transfer path from the element to the material becomes so important. The more efficient the heat transfer, the less the temperature difference between the heater and the process. The medium plays a key role in the design of a thermal system, as seen in more detail later. Calculating the wattage requirement, the selection of the watt density, sheath material and the heater type are integral in the decision as to how to apply the heat to a process. **OGDEN** has been instrumental in providing information and assisting in the design of thousands of process heat and control applications. If the information for a particular application is not included here, contact **OGDEN**. With over 50 years of experience on file, **OGDEN** may already have solved the problem.

# THERMAL SYSTEM DESIGN

In industrial processes, temperature is often the most important variable to control. Temperature variations cause changes in the chemical or physical state of most substances, resulting in changes in flow, viscosity, pressure, level or humidity. An arrangement of components designed to supply controlled heat is a Thermal System. The most sensitive control will not provide acceptable results if careful consideration is not given to the entire system design. As technology has focused increasingly on the application of electronics, control systems can be required to collect and retrieve data and communicate with computers or other controls. Even as industry moves toward the completely automated factory, process temperature control utilizes the same principles and theories whether accomplished by microprocessor or mechanically actuated thermostat.

## THERMAL SYSTEM COMPONENTS

The four elements comprising a thermal system are:

- 1.) The work or load.
- 2.) The heat source.
- 3.) The heat transfer medium.
- 4.) The control system.

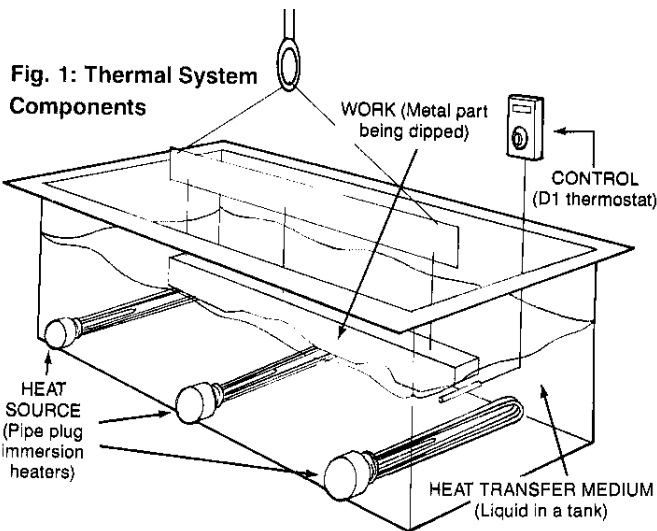

- 1.) The work is the material or product being processed. The heat demand may be steady, meaning that the material must be maintained at a constant temperature for a specified period of time. A bacteria culture in an incubating oven is an example of a steady system.

Often the heat demand is variable and cyclic. In this dynamic system, cold material enters the system for processing, absorbs heat, is removed, then replaced in the system by more cold material. An example of a variable or dynamic system is plastic injection molding equipment. The mold receives plastic material, heats, forms, cures then ejects the finished part. The process is repeated again and again.

- 2.) The heat source is the device that provides heat to the system. The source may be electric heaters, oil or gas fired systems, steam, or the process may be exothermic in that the system generates its own heat.
- 3.) The heat transfer medium is a solid, liquid or gas which transmits the heat generated from the heat source to the work. The transfer characteristics or conductivity of the material are significant in determining how fast temperature changes travel through the system, and thus, how close the system can be controlled.
- 4.) The control system includes the instrument that directs whether heat is on or off, depending on the difference between the desired temperature or control set point and the actual temperature.

## FACTORS AFFECTING SYSTEM ACCURACY

A product within acceptable quality tolerances with lowest possible scrap levels are the ultimate measures of system accuracy. Generally, a constant mean temperature and the system bandwidth determine accuracy. The system bandwidth is the temperature variance measured at the work (Fig. 2). Several factors affect the accuracy of the system.

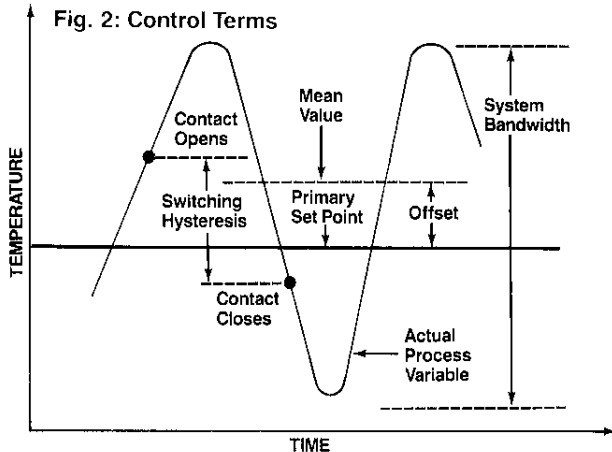

Thermal Lag is the time delay for a temperature change in one part of the system to be recognized in another part of the system. As power is applied to the heat source, a temperature rise will occur in the transfer medium in the area of the heat source, and then flow to other parts of the system. The Temperature Gradient is the range of temperatures at different locations in the system measured at the same time. Both thermal lag and temperature gradients are influenced by the conductivity of the transfer medium. Conductivity is the measure of the rate at which heat travels through a medium. See Chart 11T.

Cost considerations, thermal properties, availability and the application determine what material is most practical for use as a heat transfer medium.

The application will also determine what method of heat transfer is most practical. Conduction takes place in solids, liquids and gases, and is the transfer of heat from one material, at a given temperature, to another material at a lower temperature while in direct contact with each other.

Natural convection occurs in a liquid or a gas when heat is generated from the source causing the surrounding mass to become warm and expand. The mass decreases in density (becomes lighter), mixes with and warms the cooler mass. Forced convection can be produced by mechanically mixing the warm with the cool mass.

The transfer of heat from one body to another by emitting and absorbing radiant energy is the third method of heat transfer. No transfer medium is required, for an electromagnetic wave phenomena similar to light carries energy from a radiant heat source, passes some distance through the surrounding space to the work. The work absorbs the radiant energy and converts it to molecular-vibration heat energy. An oven utilizing tubular heaters may receive heat by all three methods. See section on Process Infrared Heating. The following heat transfer medium comparison list is in order of descending preference:

- Well agitated liquids*
- Rapidly moving gases*
- High conductivity metals*
- Low conductivity metals*
- Stagnant gas*
- Stagnant liquid*

Temperature gradients can be observed by measuring the temperature at different points in the thermal system at the same time. Starting at the heat source, the temperature would decrease progressively as you move to the edge. Every thermal system has a gradient at all times because of heat source cycling and heat losses. These changes are not transmitted or compensated for immediately throughout the system. Some gradient is necessary for heat flow, since heat can only be conducted, convected or radiated to areas lower in temperature.

Also inevitable in every system is the delay in the distribution of heat. Thermal Lag is influenced by the distance between the heat source and the work and the heat conduction capacity of the transfer medium. Thermal Lag delays information about temperature changes in the system to the control. This delay can prevent the control from sensing a need for heat soon enough, resulting in temperature undershoot. Thermal Lag can also delay the arrival of heat at the work long enough to where the heat source has produced more than what is required, producing temperature overshoot. Both overshoot and undershoot can create too large a system bandwidth, and unsatisfactory control.

Temperature gradients and thermal lag exist and are necessary to an extent as stated, but can be reduced for more accurate control. Applying as much insulation as practical to reduce heat losses from the system is the first step.

The location of the heat source and control sensor relative to the work can produce a wide range of accuracies. It is ideal to group these components in a compact area. The short distance from the heat source and control sensor to the work would enable heat requirements to be detected and responded to quickly producing the ultimate system bandwidth and a constant mean temperature (Fig. 5a). As this placement is often not practical due to the size of a system, a compromise in the placement of the component is necessary.

Maintaining a narrow bandwidth may be important in processes which are being heated close to decomposition, vaporization or other critical points. A narrow bandwidth does not guarantee perfect control, however, since the mean temperature can drift (offset or droop) (Fig. 2).

Where the heat demand is variable, the best results can be achieved by placing the control sensor closer to the work. The difference between the heat source and the control sensor is significant, causing thermal lag and sizable temperature overshoot at the work. The control selected should have compensating features (PID) for this situation (Fig. 5b).

Where the heat demand is steady, the sensor should be placed closer to the heat source. The short distance between the heat source and control sensor will allow minimal thermal lag and reduced potential for temperature overshoot and undershoot. Temperature changes are quickly detected (Fig. 5c).

When a system is both steady and variable, placing the sensor mid-way between the heat source and the work will reduce thermal lag. Some overshoot and undershoot will occur. For this arrangement, the control should also have compensating features (PID) (Fig. 5d).

Matching the wattage requirement of the system with the capacity of the heat source will also help to achieve the best possible temperature control (Fig. 6). When the desired operating temperature (set point) is reached, the heat source should be on 50% of the time. Heat loss from the thermal system, voltage fluctuations, changes in ambient temperatures, and other process upsets can also affect heat balance. Allowances need to be made for these factors when determining wattage requirements and the heat source.

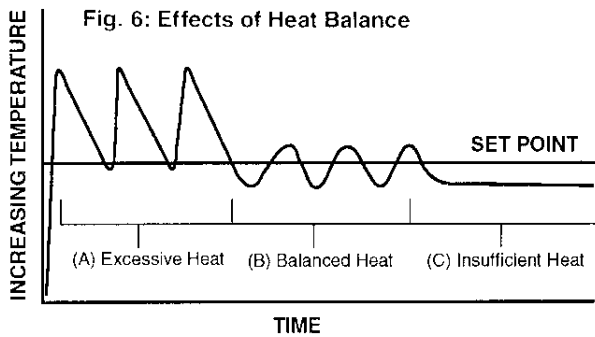
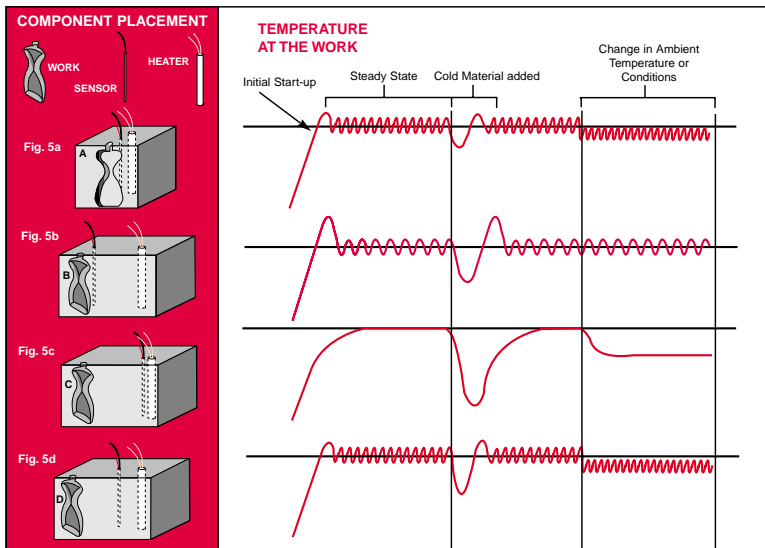

In general, if after system start-up the heat source is on more than 60% of the time, the wattage rating should be increased. If the heat source is on less than 40% of the time, the rating should be decreased. Heat conductivity is most efficient when good contact exists between the heat source and the material being heated. Rather than one large heater, several smaller rated heaters to better distribute heat throughout the system will further reduce temperature gradients (Fig. 7).

Fig. 7: Effects of Distributed Heat Source

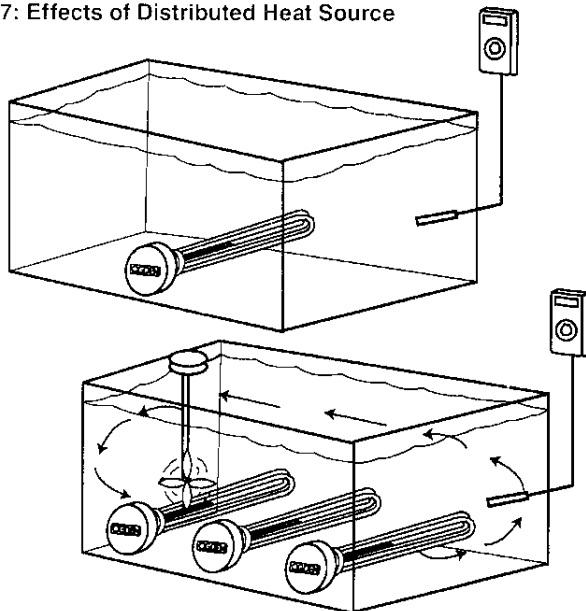

# SELECTION OF TEMPERATURE CONTROL

The temperature control may be the first suspect if a system fails to perform to expectations. As can be seen, there are many factors to be considered in designing an accurately controlled thermal system. However, the control does have an exceptional responsibility in maintaining system accuracy and can compensate for inefficiencies and errors in other parts of the system.

Certain applications such as radiant heating can maintain adequate control with manual adjustments. An Open Loop temperature control system requires continual process monitoring by an operator.

An autotransformer or variac adjusts the voltage input from 0–100% to the heat source.

An infinite control or simmerstat provides a range of control from off to full heat by switching at short, definite time intervals.

Timers control direct current to the heat source based upon intervals of time.

A trial and error method, most process control requirements are too sophisticated for Open Loop systems.

A Closed Loop Control System utilizes a feedback sensor to automatically monitor the process temperature. The control interprets the signal from the sensor then directs the output device to switch power on or off to the heat source. The output device is either an electro mechanical relay, mercury displacement relay, solid state relay (SSR) or silicone controlled rectifier (SCR). The sensor in an electronic control system is a thermocouple, RTD or thermistor. See each catalog section for complete description.

Fig. 8: Closed Loop Control System

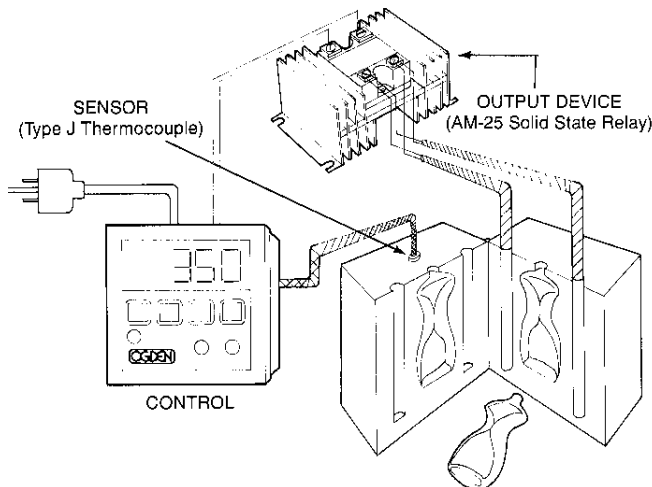

Control accuracy in the following discussion will refer to the control's capabilities, not including factors existing in the rest of the thermal system.

Resolution sensitivity is one measure of control accuracy. Expressed as a percentage of the control's temperature range, resolution sensitivity is the amount of temperature change that must occur before the control reacts.

Speed of response is the time needed for a temperature change occurring at the sensor to be translated into control action.

Indication and set point accuracy are expressed in degrees or percent of temperature range. Indication accuracy is the possible amount of error between the temperature displayed and the actual temperature. Set point accuracy is the possi-

ble error between the temperature set point and the actual temperature being controlled.

Indication and set point resolution is expressed the same as accuracy and is the smallest change that can be indicated or set.

Repeatability is the measure of the maximum sensor or deviation that can occur among output measurements under identical conditions at two or several different times.

The selection of the proper control is determined by examining the previous factors, what type of accuracy is required, and cost. It is possible to set-up a control system utilizing an electronic control for almost the same cost as a much less sensitive mechanical thermostat. For that reason, plus superior accuracy, electronic controls should be considered for most applications.

Features include LED indications, digital set points and, in some models, the ability to tune the control to compensate and respond to process upsets and variables for a specific application.

## CONTROL MODES

The action of an On/Off control mode is that the output device is either full on or full off. Full heat is applied whether the process temperature is 5° or 50° below set point. The operating differential or hysteresis is designed into the control (in some cases, the hysteresis is adjustable), and is the area between the on and off switching points where there is no control action. Temperature is always controlled around the set point and overshoot and undershoot will exist in On/Off controls. The extent will depend upon all other characteristics of the thermal system (Fig. 9).

Fig. 9: On-Off

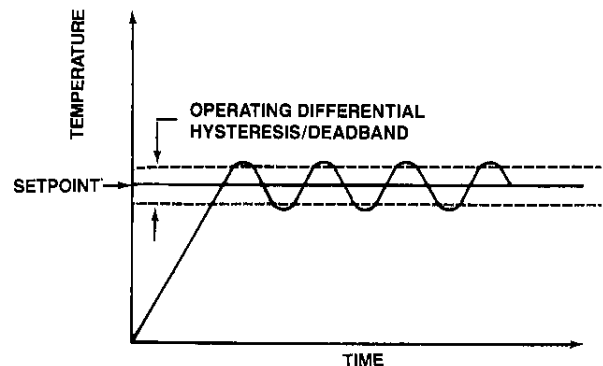

If the system requires greater accuracy than an on/off control, time proportioning will provide more precise process temperature control. Time proportioning occurs within a range of temperatures called the proportioning band. The proportioning band is either a fixed percentage of the temperature range or is adjustable. In the center of the proportioning band is the set point. When the process temperature enters the proportioning band, the output device is switched on and off at the established cycle time (2 seconds, 20 seconds or adjustable). "On time" is a greater percentage of cycle time at the lower span of the band. As the set point is approached, "Off time" is increased. The change in output delivered provides a throttling effect and less temperature overshoot (Fig. 10). The cycling will continue until equal on and off times exist.

When a current input signal is used, such as 4–20 milliamps to control an SCR or valve, then the control mode is true proportional. In true proportioning, the controlled element

(SCR or valve) can be from 0–100% on or open, as required by the size of the deviation from the set point.

**Fig. 10: Time Proportioning**

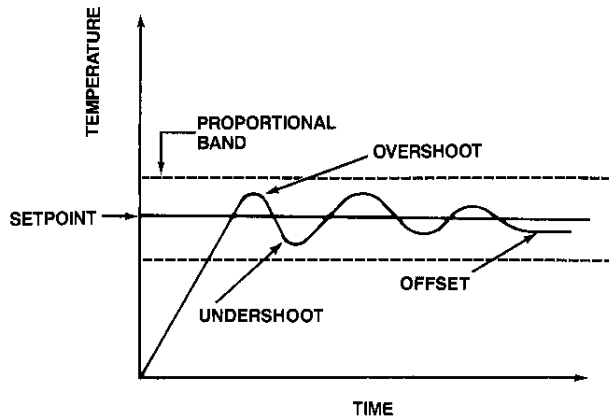

An inherent limitation in both time and true proportioning is that the system stabilizes at a temperature below or above the set point. A sudden increase in the amount of material being processed or ambient temperature changes can also cause this offset. If the offset cannot be tolerated, a manual reset dial on many controls can be adjusted to bring the process temperature to the set point (Fig. 11). An automatic reset or integral mode is a compensating feature on many controls that will adjust for the offset condition. The integral function involves moving the proportional band towards the offset to escort the process temperature back to the set point. The correction is made according to the size and the time involved for the reset to occur. Anti-reset windup by design allows the integral function to occur only in the proportional band, preventing a large reset action that would result in large over and undershoots during system start-up or work load changes.

**Fig. 11: Time Proportioning with Manual Reset**

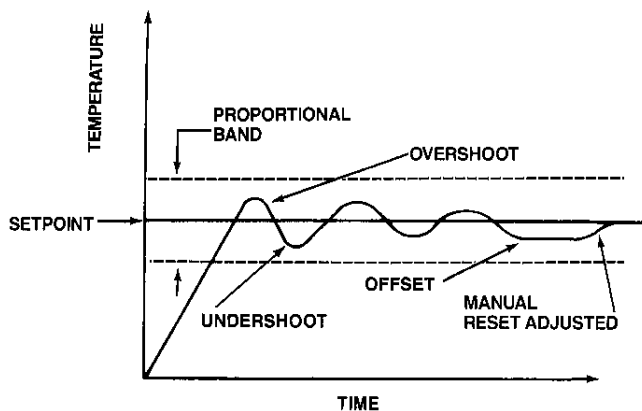

An anticipating function that measures the rate or time involved in a change in process temperature is derivative or rate. The derivative determines the size of the corrective action to be taken, causing an increase in the proportioning action to slow the change.

The integral and derivative modes work together to prevent over and undershoots in proportioning controls during system start-up or work load changes (Fig. 12).

While proportional, integral, and derivative (PID) modes suggest that these functions would be automatic, adjusting or tuning is required. Although it is theoretically possible to calculate the PID constants appropriate for a particular application, constants are selected by taking measurements and making adjustments. Each particular ETR Temperature Control User Manual contains information for control set-up, parameter selection and adjusting. Automatic or self tuning controls are microprocessor based and contain computer software that automatically calculates and sets the best PID parameters based upon the dynamics of the particular application. As manual tuning efforts are time consuming and require experienced personnel, automatic tuning controls may be cost effective. Often these controls can interface with computers, bringing process temperature into computer integrated manufacturing systems.

**Fig. 12: PID—Time Proportioning with Integral and Derivative**

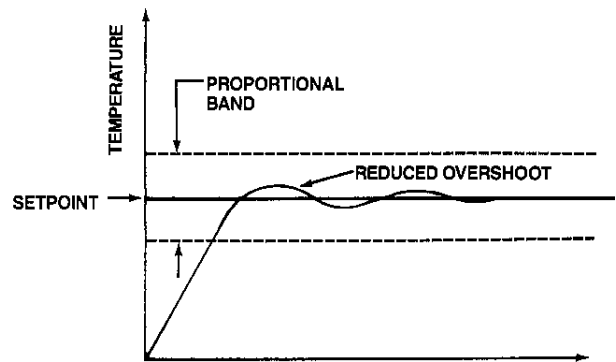
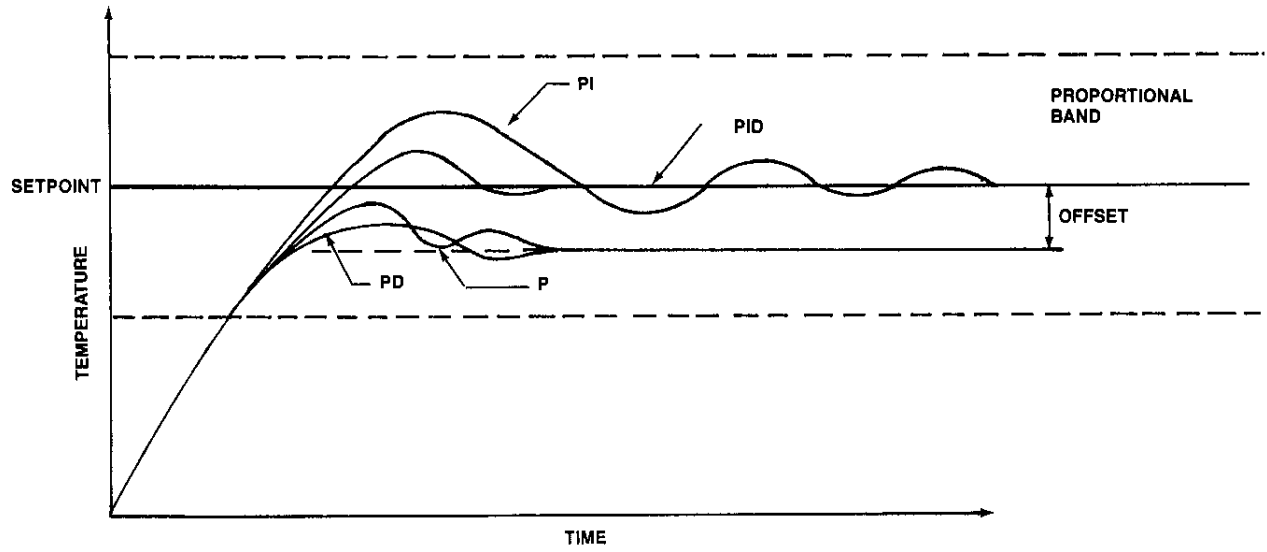
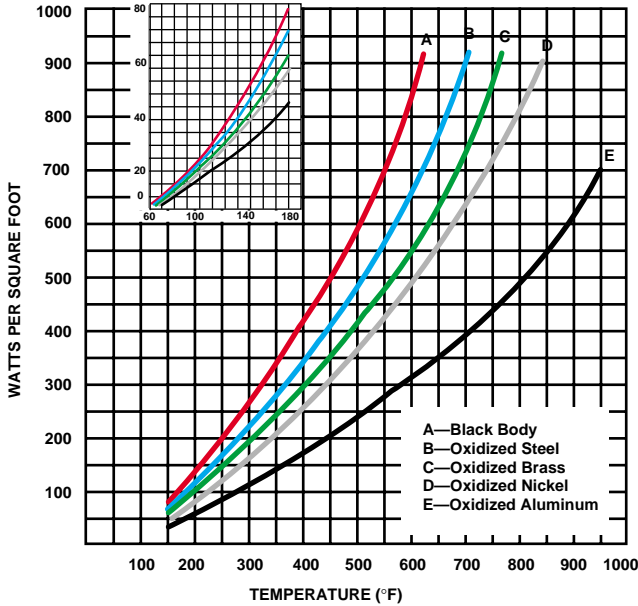

Fig. 13: Response of a Typical Control System Using Various Control Modes



# GUIDES FOR ESTIMATING HEAT LOSSES

## 1T: Heat Losses From Uninsulated Metal Surfaces



Radiant and convection heat losses are combined. Based upon 70°F ambient. For horizontal bottom surface, use ½ figure from graph.

## 2T: Heat Losses From Insulated Surfaces

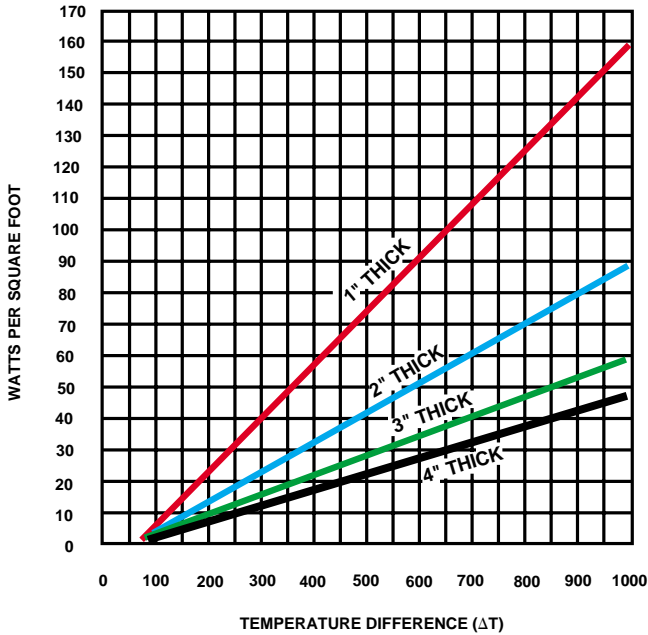

Radiant and convection heat losses are combined. Based upon 70°F ambient temperature with ceramic fiber insulation. For horizontal bottom surface, use ½ of figure from graph.

## 3T: Heat Losses From Oil and Paraffin Surfaces

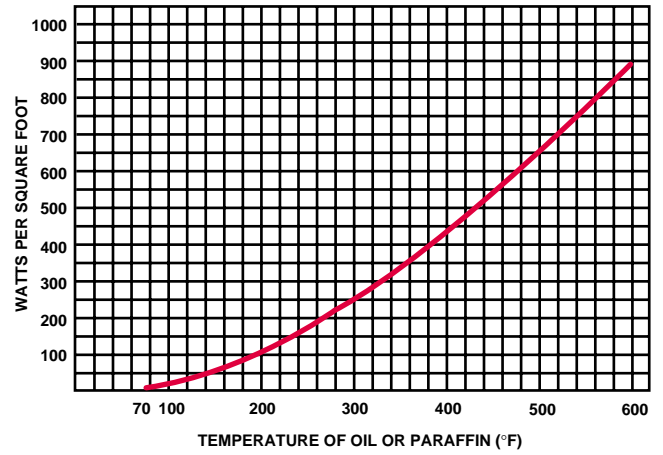

## 4T: Heat Losses From Water Surfaces

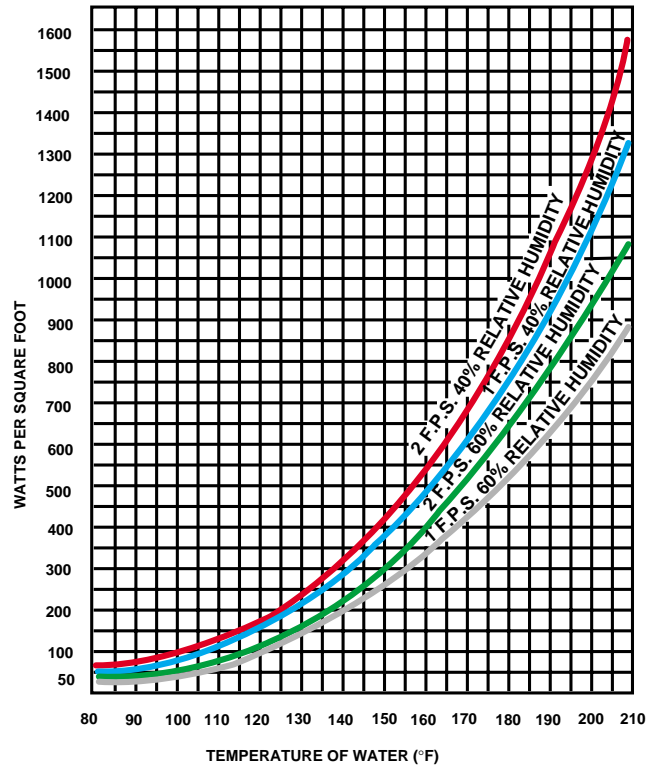

## 5T: Heat Losses From Molten Metal Surfaces (Lead, Babbit, Type Metal, Tin, etc.)

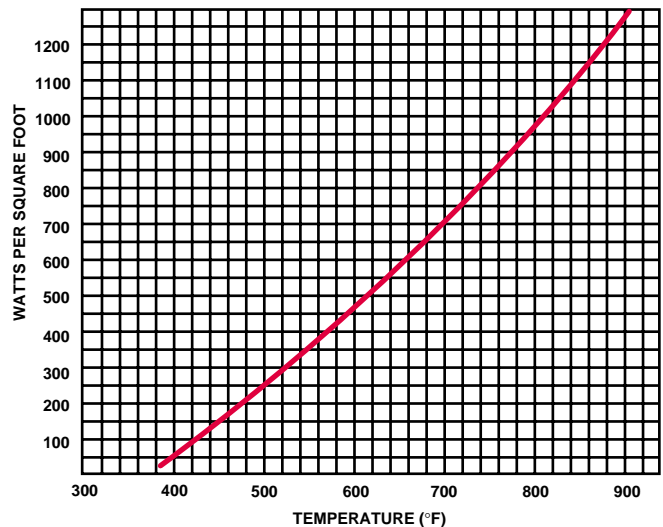

# PHYSICAL PROPERTIES OF MATERIALS

## 6T: Metals and non-Metallic Solids

SUBSTANCE	Specific Heat	Heat of Fusion Btu/lb.	Melting Point °F	Density—Weight in lbs./cu. ft.
Aluminum 2024-T3	.24	167	935	173
Aluminum 1100-0	.24	169	1190	169
Antimony	.23	25	1166	423
Asbestos Cement Board	.25 ±	..	...	121
Asphalt	.40	40	250	131
Bakelite Resin, Pure	.3-4	..	...	74-81
Barium	.068	..	1562	225
Beeswax	...	75	144	60.5
Beryllium	.052	..	2345	113.5
Bismuth	.031	23	520	612
Boron	.309	..	4172	144
Brass, 70%	.096	..	1750	532
Brickwork & Masonry	.220	..	...	131
Bronze (75%Cu; 25%Sn)	.082	75	1832	541
Cadmium	.055	23.8	610	540
Calcium	.149	140	1564	96.7
Calcium Chloride	.17	..	1422	157
Carbon	.280	..	6700	138
Cement, Portland, Loose	.19	..	...	94
Cerafelt Insulation	.25 @ 1000°F	..	...	3
Ceramic Fiber	.27	..	...	4-10
Chalk	.215	..	...	112-175
Chromium	.11	..	2822	450
Clay	.224	..	3160	90
Coal	.32	..	...	80
Coal Tar	.35-.45	..	...	78
Cobalt	.099	115.2	2696	554
Coke	.265	..	...	62-88
Concrete, Cinder	.16	..	...	100
Concrete, Stone	.156	..	...	144
Copper	.095	91.1	1981	556
Cork	.36	..	...	13.5
Cotton (Flax, Hemp)	.31	..	...	92.4
Delrin	.350	..	...	88.1
Firebrick, Fireclay	.243	..	2900	137-150
Firebrick, Silica	.258	..	3000	144-162
Glass	.20	..	2200 ±	164
Gold	.032	29.0	1945	1206
Granite	.192	..	...	160-175
Graphite	.20	..	...	130
Ice	.53	144	32	56.0
Incoloy 800	.13	..	2475-2525	501
Inconel 600	.126	..	2500	525
Invar (36%Ni)	.126	..	2600	506
Iron, Cast	.12	..	2150	449
Iron, Wrought	.12	..	2800	480
Isoprene, Rubber	.48	..	...	58
Lead, Solid	.032	11.3	620	708
Limestone	.217	..	...	130-175
Lithium	.79	59	367	367
Manganese	.115	116	2268	463
Magnesium	.27	160	1202	109
Magnesia, 85%	.222	..	5070	19
Mg O (Compacted)	.209	..	...	194
Mercury	.033	5	-38	844
Mica	.21	..	...	176
Molybdenum	.061	126	4750	638

SUBSTANCE	Specific Heat	Heat of Fusion Btu/lb.	Melting Point °F	Density—Weight in lbs./cu. ft.
Monel 400	.11	..	2370	551
Nickel 200	.12	133	2615	555
Nichrome (80% Ni.-20% Cr.)	.11	..	2550	522
Paper	.45	..	...	58.8
Paraffin	.69	63	133	55.3
Pitch (Hard)	...	..	300 ±	83
Plastics:				
ABS	.35	..	...	69-76
Acrylic	.34	..	...	69-74
Cellulose Acetate	.3-5	..	...	76-83
Cellulose Acetate Butyrate	.3-4	..	...	74
Epoxy	.25-.3	..	...	66-88
Fluoroplastics	.28	..	...	131-150
Nylon	.3-5	..	...	67-72
Phenolic	.35	..	...	85-124
Polycarbonate	.3	..	...	74-78
Polyester	.2-35	..	...	66-92
Polyethylene	.54	..	...	57-60
Polyimides	.27-.31	..	...	90
Polypropylene	.46	..	...	55-57
Polystyrene	.32	..	...	66
Polyvinyl Chloride Acetate	.2-3	..	...	72-99
Platinum	.035	49	3225	1339
Porcelain	.26	..	...	145-155
Potassium	.058	26.2	146	750
Potassium Chloride	.17	..	1454	124
Potassium Nitrate	.26	..	633	132
Quartz	.26	..	...	138
Rhodium	.059	..	3570	776
Rubber	.44	..	...	76.0
Rubber, Synthetic	.40	..	...	58
Silicone Rubber	.45	..	...	78
Silicon	.162	..	2570	14.5
Silver	.057	38	1760	665
Sodium	.295	49.5	207	60
Solder (50% Pb-50% Sn.)	.051	17	361	558
Steatite	.20	..	...	162
Steel Mild	.122	..	2760	491
Steel S. 304	.12	..	2550	494
Steel S. 430	.11	..	2650	475
Sulfur	.175	17	246	130
Sugar	.30	..	320	105
Tallow	...	..	90 +	60.0
Tantalum	.035	..	5425	104
Teflon	.25	..	...	135
Tin, Solid	.065	261	450	454
Titanium 99.0%	.13	..	3035	283
Tungsten	.032	79	6170	1200
Type Metal (85% Pb.-13% Sb.)	.040	14 +	500	669
Uranium	.028	..	3075	1170
Vinyl	.3-5	..	...	79.5
Wood (Pine)	.45 ±	..	...	34
Wood (Oak)	.57	..	...	50
Zirconium	.066	108	3350	400
Zinc	.096	43.3	787	445

± Estimated

## 7T: Metals in Liquid State

SUBSTANCE	Specific Heat	Heat of Fusion Btu/lb.	Melting Point °F	Temperature °F	Density—Weight in lbs./cu. ft.
Aluminum	.26	173	1220.4	1220	148.6
	.26	...	...	1292	147.7
	.26	...	...	1454	...
Bismuth	.034 @ 520° F	21.6	520	572	626.2
	.0354	...	...	752	618.7
	.0376	...	...	1112	603.1
Cadmium	.0632	23.8	609	626	500
	.0632	...	...	662	498.8
	.0632	...	...	680	...
	.0632	...	...	752	495
Gold	.0355	26.9	1945	2012	1076
Lead	.038	10.6	621	700	655.5
	.037	...	...	932	648.7
Lithium	1.0	284.4	354	392	31.7
	1.0	...	...	752	31
Magnesium	.317	148	1204	1204	98.
	...	...	...	1328	94.3
	.321	...	...	1341	...

SUBSTANCE	Specific Heat	Heat of Fusion Btu/lb.	Melting Point °F	Temperature °F	Density—Weight in lbs./cu. ft.
Mercury	.03334	5	-38	32	...
	.03279	...	...	212	833.6
	...	...	...	320	...
	.03245	...	...	392	818.8
Potassium	.1901	26.3	147	300	50.6
	.1826	...	...	752	46.6
Silver	.0692	44.8	1761	1761	580.6
	.0692	...	...	1832	578.1
	.0692	...	...	2000	574.4
Sodium	.331	48.7	208	212	57.9
	.320	...	...	400	56.2
	.301	...	...	752	53.3
Solder .5 Sn, .5 Pb	.0556	17	421	...	...
.6 Sn, .4 Pb	.0584	28	375	...	...
Tin	.058	26.1	449	482	...
	...	...	...	768	426.6
	...	...	...	783	...
Zinc	.12	43.9	787	787	432
	...	...	...	932	...
	.117	...	...	1112	425

### 8T: Liquids

SUBSTANCE	Specific Heat	Heat of Vaporization Btu/lb.	Boiling Point °F	Density— Weight in lbs./cu.ft.	Weight in lbs./gal.
Acetic Acid, 100%	.48	175	245	65.4	8.74
Acetone, 100%	.514	225	133	49	6.5
Allyl Alcohol	.665	293	207	55	7.35
Ammonia, 100%	1.1	589	-27	47.9	6.4
Amyl Alcohol	.65	216	280	55	7.35
Aniline	.514	198	63	64.6	8.63
Arochier Oil	.28		650	89.7	12.00
Brine Sodium Chloride, 25%	.786	730	220	74.1	9.9
Butyl Alcohol	.687	254	244	45.3	6.0
Butyric Acid	.515		345	50.4	6.73
Carbon Tetrachloride	.21		170	98.5	13.16
Corn Syrup, Dextrose	.65 ±		231	87.8	11.73
Cottonseed Oil	.47			59.2	7.9
Ether	.503	160	95	46	6.14
Ethyl Acetate	.475	183.5	180	51.5	6.88
Ethyl Alcohol, 95%	.60	370		50.4	6.74
Ethyl Bromide	.215	108	101	90.5	12.1
Ethyl Chloride	.367	166.5	54	57	7.62
Ethyl Iodide	.161	81.3	160	113	15.1
Ethylene Bromide	.172	83	270	120	16.0
Ethylene Chloride	.299	139	240	71.7	9.58
Ethylene Glycol	.555		387	70.0	9.36
Fatty Acid-Aleic	.7 ±		547	55.4	7.4
Fatty Acid-Palmitic	.653		520	53.1	7.1
Fatty Acid-Stearic	.550		721	52.8	7.06
Formic Acid	.525	216	213	69.2	9.25
Freon 11	.208		74.9	92.1	12.3
Freon 12	.232	62	-21.6	81.8	10.93
Freon 22	.300		-41.36	74.53	9.96
Fruit, Fresh, Avg.	.88			50-60	6.7-8.0
Glycerine	.58		556	78.7	10.5
Heptane	.49	137.1	210	38.2	5.1
Hexane	.6	142.5	155	38.2	5.1
Honey	.34				
Hydrochloric Acid, 10%	.93		221	66.5	8.89
Lard	.64			57.4	7.67
Linseed Oil	.44		552	57.9	7.74
Maple Syrup	.48				
Mercury	.033	117	675	845	113.0
Methyl Acetate	.47	176.5	133	54.8	7.3
Methyl Chloroform	.26	95	165	82.7	11.0
Methylene Chloride	.288	142	104	82.6	11.0
Milk, 3.5%	.90			64.2	8.58
Molasses	.60		220 ±	87.4	11.68
Nitric Acid, 7%	.92	918	220	64.7	8.65
Nitric Acid, 95%	.5	207	187	93.5	12.5
Nitrobenzene	.35	142.2	412		
Olive Oil	.47		570	58	7.75
Perchlorethylene	.21	90	250	101.3	13.54

SUBSTANCE	Specific Heat	Heat of Vaporization Btu/lb.	Boiling Point °F	Density— Weight in lbs./cu.ft.	Weight in lbs./gal.
Petroleum Products:					
Asphalt	.42			62.3	8.33
Benzene	.42	170	175	56	7.48
Fuel Oils:					
Fuel Oil #1 (Kerosene)	.47	86	**440 ±	50.5	6.75
Fuel Oil #2	.44			53.9	7.2
Fuel Oil Medium #3, #4	.425	67	**580 ±	55.7	7.44
Fuel Oil Heavy #5, #6	.41			58.9	7.87
Gasoline	.53	116	**280 ±	41-43	5.5-5.75
Machine/Lube Oils:					
SAE 10-30	.43			55.4	7.4
SAE 40-50	.43			55.4	7.4
Napthalene	.396	103	424 +	54.1	7.23
Paraffin, Melted (150°F +)	.69	70	572	56	7.5
Propane (Compressed)	.576		-48.1	.13	.02
Toluene	.42			53.7	7.18
Transformer Oils	.42			56.3	7.5
Phenol (Carbolic Acid)	.56		346	66.6	8.9
Phosphoric Acid, 10%	.93			65.4	8.74
Phosphoric Acid, 20%	.85			69.1	9.24
Polyurethane Foam Components:					
Part A Isocyanate	.6			77	10.3
Part B Polyol Resin	.7			74.8	10.0
Potassium (1000°F)	.18	893	1400	44.6	5.96
Propionic Acid	.56	177.8	286	61.8	8.26
Propyl Alcohol	.57	295.2	208	50.2	6.7
Sea Water	.94			64.2	8.58
Sodium (1000°F)	.30	1810	1638	51.2	6.84
Sodium Hydroxide (Caustic Soda)					
30% Sol.	.84			82.9	11.08
50% Sol.	.78			95.4	12.75
Soybean Oil	.24-.33			57.4	7.67
Starch				95.4	12.75
Sucrose, 40% Sugar Syrup	.66		214	73.5	9.8
Sucrose, 60% Sugar Syrup	.74		218	80.4	10.75
Sulfur, Melted (500°F)	.24	120	832	112	14.97
Sulfuric Acid, 20%	.84		218	71	9.5
Sulfuric Acid, 60%	.52		282	93.5	12.5
Sulfuric Acid, 98%	.35	219	625	114.7	15.33
Trichloroethylene	.23	103	188	91.3	12.2
Trichloro-Trifluoroethane	.21	63	118	94.6	12.64
Turpentine	.42	133	319	54	7.2
Vegetable Oil	.43			57.5	7.69
Water	1.00	965	212	62.5	8.34
Xylene	.411	149.2	286	53.8	7.2

\* At or near room temperature.

\*\* Average value shown. Boils at various temperatures within the distillation range for the material.

### 9T: Gases and Vapors

SUBSTANCE	Chemical Formula or Symbol	Specific Heat at Constant Pressure	Density— Weight in lbs./cu. ft. at 70°F and Atmospheric Pressure	Specific Gravity Relative to Air
Acetylene (ethyne)	C <sub>2</sub> H <sub>2</sub>	.35	.0682	.907
Air		.24	.075	1.00
Ammonia	NH <sub>3</sub>	.523	.0448	.596
Argon	A	.124	.1037	1.379
Butane	C <sub>4</sub> H <sub>10</sub>	.395	.1554	2.067
Carbon Dioxide	CO <sub>2</sub>	.199	.115	1.529
Carbon Monoxide	CO	.248	.0727	.967
Chlorine	Cl <sub>2</sub>	.115	.1869	2.486
Ethane	C <sub>2</sub> H <sub>6</sub>	.386	.0789	1.049
Ethylene	C <sub>2</sub> H <sub>4</sub>	.40	.0733	.975
Helium	He	1.25	.0104	.1381
Hydrogen Chloride	HCl	.191	.0954	1.268
Hydrogen	H <sub>2</sub>	3.42	.0052	.0695
Hydrogen Sulphide	H <sub>2</sub> S	.243	.0895	1.19

SUBSTANCE	Chemical Formula or Symbol	Specific Heat at Constant Pressure	Density— Weight in lbs./cu. ft. at 70°F and Atmospheric Pressure	Specific Gravity Relative to Air
Methane	CH <sub>4</sub>	.593	.0417	.554
Methyl Chloride	CH <sub>3</sub> Cl	.24	.1342	1.785
Natural Gas		.56	.0502	.667
Nitric Oxide	NO	.231	.078	1.037
Nitrogen	N <sub>2</sub>	.247	.0727	.967
Nitrous Oxide	N <sub>2</sub> O	.221	.1151	1.53
Oxygen	O <sub>2</sub>	.217	.0831	1.105
Propane	C <sub>3</sub> H <sub>8</sub>	.393	.1175	1.562
Propene (propylene)	C <sub>3</sub> H <sub>6</sub>	.358	.1091	1.451
Sulpher Dioxide	SO <sub>2</sub>	.154	.1703	2.264
Water Vapor at 212 deg. F	H <sub>2</sub> O	.482	.037	.489

Natural Gas values are representative. Specific contents of samplings are required for exact characteristics.

**10T: Air Densities and Properties at Various Temperatures and Pressures**

The density of gases and vapors other than air can be determined by multiplying the figure chosen from below,

by the Specific Gravity Relative to Air column for the substance required from 9T.

Temp. ° F	Specific Heat Btu/lb.°F	Gauge Pressure, PSI at 1 Atmosphere																		
		0	5	10	20	30	40	50	60	80	100	120	140	160	180	200	230	250	275	300
0	.240	.086	.116	.145	.204	.263	.321	.380	.439	.556	.674	.791	.909	1.026	1.144	1.261	1.437	1.555	1.701	1.848
10	.240	.085	.113	.142	.199	.257	.314	.372	.429	.544	.659	.774	.889	1.004	1.119	1.234	1.407	1.522	1.665	1.808
20	.240	.083	.111	.139	.195	.252	.308	.364	.420	.533	.646	.758	.871	.983	1.096	1.208	1.377	1.490	1.631	1.771
30	.240	.081	.109	.136	.191	.246	.302	.357	.412	.522	.632	.743	.853	.963	1.073	1.184	1.349	1.459	1.597	1.735
40	.240	.079	.106	.133	.187	.242	.296	.350	.404	.512	.620	.728	.836	.944	1.052	1.160	1.322	1.430	1.565	1.700
50	.240	.078	.104	.131	.184	.237	.290	.343	.396	.502	.608	.714	.820	.925	1.031	1.137	1.296	1.402	1.535	1.667
60	.240	.076	.102	.128	.180	.232	.284	.336	.388	.492	.596	.700	.804	.908	1.012	1.115	1.271	1.375	1.505	1.635
70	.240	.075	.100	.126	.177	.228	.279	.330	.381	.483	.585	.687	.789	.890	.992	1.094	1.247	1.349	1.477	1.600
80	.240	.074	.099	.124	.174	.224	.274	.324	.374	.474	.574	.674	.774	.874	.974	1.074	1.224	1.324	1.449	1.574
90	.240	.072	.097	.121	.170	.220	.269	.318	.367	.465	.563	.662	.760	.858	.956	1.055	1.202	1.300	1.423	1.546
100	.240	.071	.095	.119	.167	.216	.264	.312	.360	.457	.553	.650	.746	.842	.939	1.036	1.181	1.277	1.398	1.518
120	.240	.068	.092	.115	.162	.208	.255	.301	.348	.441	.534	.627	.721	.814	.907	1.000	1.140	1.233	1.349	1.466
140	.240	.066	.089	.111	.156	.201	.247	.291	.336	.426	.516	.607	.697	.787	.877	.967	1.102	1.192	1.304	1.417
160	.241	.064	.086	.108	.151	.195	.239	.282	.326	.413	.500	.587	.674	.761	.848	.936	1.067	1.153	1.262	1.371
180	.241	.062	.083	.104	.146	.189	.231	.273	.315	.400	.484	.570	.653	.737	.822	.906	1.033	1.117	1.223	1.328
200	.242	.060	.081	.101	.142	.183	.224	.265	.306	.388	.470	.551	.633	.715	.797	.879	1.002	1.084	1.186	1.288
220	.242	.058	.078	.098	.138	.178	.217	.257	.297	.376	.456	.535	.615	.694	.774	.853	.972	1.052	1.151	1.250
240	.242	.057	.076	.095	.134	.173	.211	.250	.288	.365	.443	.520	.597	.674	.751	.829	.944	1.022	1.118	1.215
260	.243	.055	.074	.093	.130	.168	.205	.243	.280	.355	.430	.505	.580	.656	.731	.806	.918	.993	1.087	1.181
280	.243	.054	.072	.090	.127	.163	.200	.236	.273	.346	.419	.492	.564	.638	.711	.784	.893	.966	1.058	1.149
300	.244	.052	.070	.088	.123	.159	.194	.230	.266	.337	.408	.479	.550	.621	.692	.763	.870	.941	1.030	1.119
320	.244	.051	.068	.086	.120	.155	.189	.224	.259	.328	.397	.467	.536	.605	.674	.744	.848	.917	1.003	1.090
340	.244	.050	.067	.083	.117	.151	.185	.219	.252	.320	.387	.455	.522	.590	.658	.725	.826	.894	.978	1.063
360	.246	.048	.065	.081	.114	.147	.180	.213	.246	.312	.378	.444	.510	.576	.641	.707	.806	.872	.954	1.037
380	.246	.047	.063	.079	.112	.144	.176	.208	.240	.305	.369	.433	.498	.562	.626	.691	.787	.851	.932	1.012
400	.247	.046	.062	.078	.109	.140	.172	.203	.235	.298	.360	.423	.486	.549	.612	.674	.769	.832	.910	.989
420	.247	.045	.060	.076	.107	.137	.168	.199	.229	.291	.352	.414	.475	.536	.598	.659	.751	.813	.889	.966
440	.247	.044	.059	.074	.104	.134	.164	.194	.224	.284	.344	.404	.464	.524	.584	.644	.735	.795	.870	.945
460	.248	.043	.058	.073	.102	.131	.161	.190	.220	.278	.337	.396	.454	.513	.572	.630	.719	.777	.851	.924
480	.248	.042	.057	.071	.100	.128	.157	.186	.215	.272	.330	.387	.445	.502	.560	.617	.703	.761	.833	.905
500	.249	.041	.055	.070	.098	.126	.154	.182	.210	.267	.323	.379	.435	.492	.548	.604	.689	.745	.815	.886
520	.249	.041	.054	.068	.096	.123	.151	.178	.206	.261	.316	.371	.426	.482	.537	.592	.675	.730	.799	.868
540	.249	.040	.053	.067	.094	.121	.148	.175	.202	.256	.310	.364	.418	.472	.526	.580	.661	.715	.783	.850
560	.250	.039	.052	.065	.092	.118	.145	.171	.198	.251	.304	.357	.410	.463	.516	.569	.648	.701	.767	.834
580	.251	.038	.051	.064	.090	.116	.142	.168	.194	.246	.298	.350	.402	.454	.506	.558	.636	.688	.753	.818
600	.252	.037	.050	.063	.088	.114	.139	.165	.190	.241	.292	.343	.394	.445	.496	.547	.624	.675	.739	.802
620	.252	.037	.049	.062	.087	.112	.137	.162	.187	.237	.287	.337	.387	.437	.487	.537	.612	.662	.725	.787
640	.252	.036	.048	.061	.085	.110	.134	.159	.183	.233	.281	.331	.380	.429	.478	.527	.601	.650	.712	.773
660	.253	.035	.048	.060	.084	.108	.132	.156	.180	.228	.277	.325	.373	.421	.470	.518	.590	.639	.699	.759
680	.252	.035	.047	.059	.082	.106	.130	.153	.177	.224	.272	.319	.367	.414	.461	.509	.580	.627	.687	.746
700	.254	.034	.046	.058	.081	.104	.127	.151	.174	.221	.267	.314	.360	.407	.453	.500	.570	.616	.675	.733
720	.254	.034	.045	.057	.079	.102	.125	.148	.171	.217	.263	.308	.354	.400	.446	.492	.560	.606	.663	.721
740	.255	.033	.044	.056	.078	.101	.123	.146	.168	.213	.258	.303	.348	.393	.438	.483	.551	.596	.652	.709
760	.256	.033	.044	.055	.077	.100	.121	.143	.165	.210	.254	.298	.343	.387	.431	.475	.542	.586	.642	.697
780	.256	.032	.043	.054	.076	.097	.119	.141	.163	.206	.250	.294	.337	.381	.424	.468	.533	.577	.631	.686
800	.257	.032	.042	.053	.074	.096	.117	.139	.160	.203	.246	.289	.332	.375	.417	.460	.525	.568	.621	.675
820	.257	.031	.042	.052	.073	.094	.115	.137	.158	.200	.242	.284	.327	.369	.411	.453	.517	.559	.611	.664
840	.257	.031	.041	.051	.072	.093	.114	.134	.155	.197	.238	.280	.322	.363	.405	.446	.508	.550	.602	.654
860	.258	.030	.040	.051	.071	.091	.112	.132	.153	.194	.235	.276	.317	.358	.399	.439	.501	.542	.593	.644
880	.259	.030	.039	.050	.070	.090	.110	.130	.151	.191	.231	.272	.312	.352	.393	.433	.494	.534	.584	.634
900	.260	.029	.039	.049	.069	.089	.109	.129	.148	.188	.228	.268	.307	.347	.387	.427	.486	.526	.575	.625
920	.260	.029	.039	.048	.068	.088	.107	.127	.146	.185	.225	.264	.303	.342	.381	.420	.479	.518	.567	.616
940	.260	.028	.038	.048	.067	.086	.106	.125	.144	.183	.221	.260	.299	.337	.376	.414	.472	.511	.559	.607
960	.261	.028	.037	.047	.066	.085	.104	.123	.142	.180	.218	.256	.294	.332	.370	.408	.466	.504	.551	.599
980	.261	.028	.037	.046	.065	.084	.103	.121	.140	.178	.215	.253	.290	.328	.365	.403	.459	.497	.544	.590
1000	.262	.027	.036	.046	.064	.083	.101	.120	.138	.175	.212	.249	.286	.323	.360	.397	.453	.490	.536	.582
1020	.262	.027	.036	.045	.063	.082	.100	.118	.136	.173	.209	.245	.282	.319	.355	.392	.447	.483	.529	.574
1040	.263	.026	.035	.044	.063	.081	.099	.117	.135	.171	.207	.243	.279	.315	.351	.387	.441	.477	.522	.567
1060	.264	.026	.035	.044	.062	.079	.097	.115	.133	.168	.204	.239	.275	.311	.346	.382	.435	.470	.515	.559
1080	.264	.026	.035	.043	.060	.078	.096	.114	.131	.166	.201	.236	.271	.306	.342	.377	.429	.464	.508	.552
1100	.265	.025	.034	.043	.060	.077	.095	.112	.129	.164	.199	.233	.268	.303	.337	.372	.424	.458	.502	.545
1120	.265	.025	.034	.042	.059	.076	.094	.111	.128	.162	.196	.230	.265	.299	.333	.367	.418	.453	.495	.538
1140	.265	.025	.033	.042	.059	.075	.092	.109	.126	.160	.194	.227	.261	.295	.329	.363	.413	.447	.489	.531
1160	.266	.025	.033	.041	.058	.075	.091	.108	.125	.158	.191	.225	.258	.291	.325	.358	.408	.441	.483	.525
1180	.266	.024	.032	.041	.057	.074	.090	.107	.123	.156	.189	.222	.255	.288	.321	.354	.403	.436	.477	.518
1200	.267	.024	.032	.040	.056	.073	.089	.105	.122	.154	.187	.219	.252	.284	.317	.349	.398	.431	.471	.512

Weight in pounds per cubic foot

## 11T:Thermal Conductivity of Various Substances

The following is a listing of the ratios of how fast heat is conducted through each material. The information is useful as a comparison of one substance to another. Large numbers indicate greater conductivity characteristics.\*

Air . . . . .0.0568	Coal . . . . .0.30	Ice . . . . .3.9	Petroleum . . . . .0.39
Aluminum . . . . .480.0	Coke, powdered . . . . .0.44	Iron, pure . . . . .161.0	Pumice stone . . . . .0.43
Antimony . . . . .44.2	Concrete, cinder . . . . .0.81	Iron, cast . . . . .109.0	Quartz, pr. to axis . . . . .30.0
Argon . . . . .0.0389	Concrete, stone . . . . .2.2	Iron, wrought . . . . .144.0	Quartz, perp. to axis . . . . .160.0
Asbestos, paper . . . . .0.6	Copper . . . . .918.0	Lamp black . . . . .0.07	Rubber, hard . . . . .0.43
Bismuth . . . . .17.7	Cotton wool . . . . .0.043	Lead . . . . .83.0	Rubber, Para . . . . .0.38
Blotting paper . . . . .0.15	Cotton batting, loose . . . . .0.11	Leather, cowhide . . . . .0.42	Sand, dry . . . . .0.86
Brass . . . . .204.0	Cotton batting, packed . . . . .0.072	Leather, chamois . . . . .0.15	Sandstone . . . . .5.5
Brick, aluminum . . . . .2.0	Earth, average . . . . .4.0	Lime . . . . .0.29	Sawdust . . . . .0.14
Brick, building . . . . .1.5	Eiderdown, loose . . . . .0.108	Linen . . . . .0.21	Silica, fused . . . . .2.55
Brick, carborundum . . . . .23.0	Eiderdown, packed . . . . .0.045	Magnesia . . . . .0.3	Silk . . . . .0.13
Brick, fire . . . . .3.1	Feathers . . . . .0.16	Magnesium, carb . . . . .0.23	Silver . . . . .974.0
Brick, graphite . . . . .25.0	Felt . . . . .0.22	Marble . . . . .8.4	Slate . . . . .4.8
Brick, magnesia . . . . .7.1	Fiber, red . . . . .1.1	Mercury . . . . .19.7	Snow . . . . .0.60
Brick, silica . . . . .2.0	Flannel . . . . .0.035	Mica . . . . .0.86	Steel . . . . .115.0
Cadmium . . . . .222.0	German silver . . . . .80.0	Nickel . . . . .142.0	Terra Cotta . . . . .2.3
Carbon gas . . . . .130.0	Glass, crown . . . . .2.5	Nitrogen . . . . .0.0524	Tin . . . . .155.0
Carbon graphite . . . . .290.0	Glass, flint . . . . .2.0	Oxygen . . . . .0.0563	Water . . . . .1.6
Carbon dioxide . . . . .0.0307	Gold, . . . . .700.0	Paper . . . . .0.31	Wood, fir, with grain . . . . .0.30
Carbon monoxide . . . . .0.0499	Granite . . . . .4.5	Paraffin . . . . .0.62	Wood, fir, cross grain . . . . .0.09
Carborundum . . . . .0.50	Gutta percha . . . . .0.48	Pasteboard . . . . .0.45	Wool, sheep . . . . .0.14
Cardboard . . . . .0.50	Gypsum . . . . .3.1	Plaster of Paris . . . . .0.42	Wool, mineral . . . . .0.11
Cement, portland . . . . .0.17	Hair . . . . .0.15	Plaster, mortar . . . . .1.3	Wool, steel . . . . .0.20
Chalk . . . . .0.28	Hair cloth, felt . . . . .0.042	Platinum . . . . .170.0	Woolen, loose, wadding . . . . .0.12
Charcoal, powdered . . . . .0.22	Helium . . . . .0.339	Plumbago . . . . .1.0	Zinc . . . . .265.0
Clinkers, small . . . . .1.1	Horn . . . . .0.087	Poplox (Na <sub>2</sub> SiO <sub>3</sub> ) . . . . .0.13	
	Hydrogen . . . . .0.327	Porcelain . . . . .4.3	

\* Expressed in gram-calories/second/square centimeter/centimeter/°C

# SHEATH TEMPERATURES RELATIVE TO WATT DENSITY

**12T:** Sheath Temperature of Tubular Elements at Various Watt Densities in Free or Forced Air at 80°F.

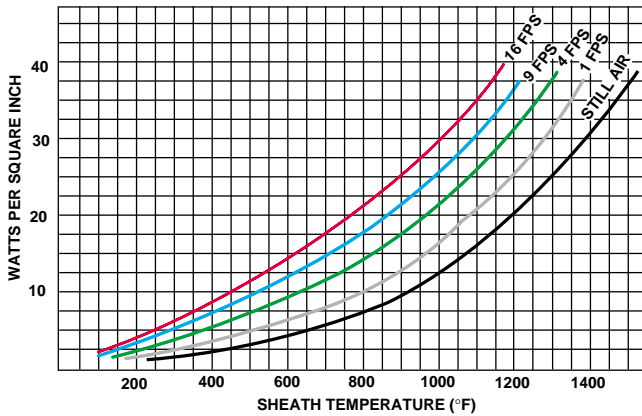

**13T:** Sheath Temperatures of Tubular Elements Clamped to a Surface at Various Ambient Temperatures and Watt Densities

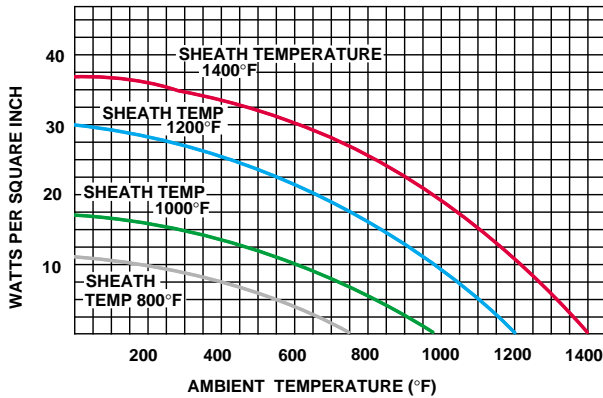

$$\text{AMBIENT TEMPERATURE} = \frac{\text{Sheath Temperature} + \text{Temperature at Process (Work)}}{2}$$

**14T:** Allowable Watt Density of Tubular Elements Operating at 800° to 1400°F Sheath Temperature for Various Temperatures in Distributed Air Velocity of 1 Fps.

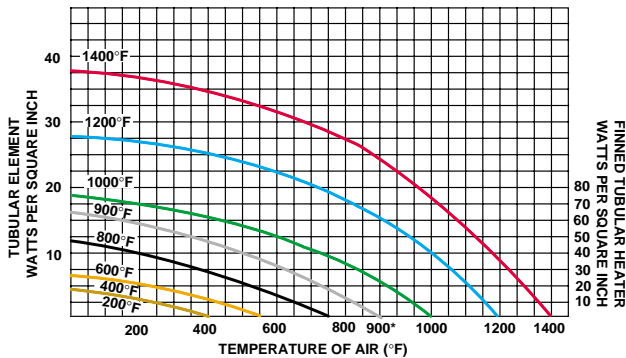

\*FINNED TUBULAR HEATER LIMIT (STEEL SHEATH AND FINS)

**15T:** Allowable Watt Density of Tubular Elements Operating at 800° to 1400°F Sheath Temperature for Various Temperatures in Distributed Air Velocity of 4 Fps.

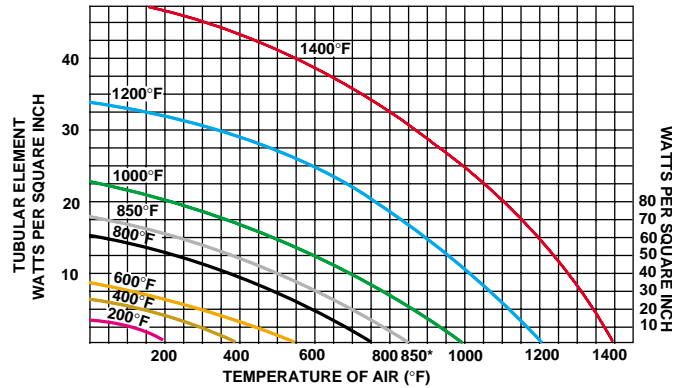

\*FINNED TUBULAR HEATER LIMIT (STEEL SHEATH AND FINS)

**16T:** Allowable Watt Density of Tubular Elements Operating at 800° to 1400°F Sheath Temperature for Various Temperatures in Distributed Air Velocity of 9 Fps.

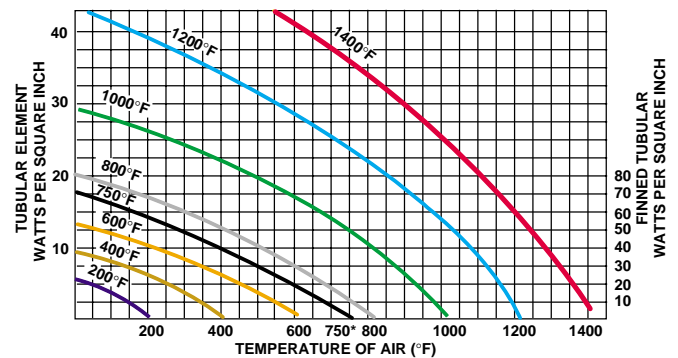

\*FINNED TUBULAR HEATER LIMIT (STEEL SHEATH AND FINS)

**17T:** Allowable Watt Density of Tubular Elements Operating at 800° to 1400°F Sheath Temperature for Various Temperatures in Distributed Air Velocity of 16 Fps.

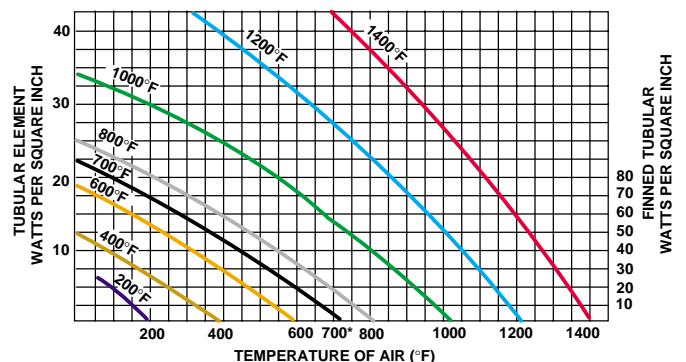

\*FINNED TUBULAR HEATER LIMIT (STEEL SHEATH AND FINS)

**18T: Sheath Temperature of HD Strip Heaters Clamped to a Surface at Various Ambient Temperatures and Watt Densities<sup>1</sup>**

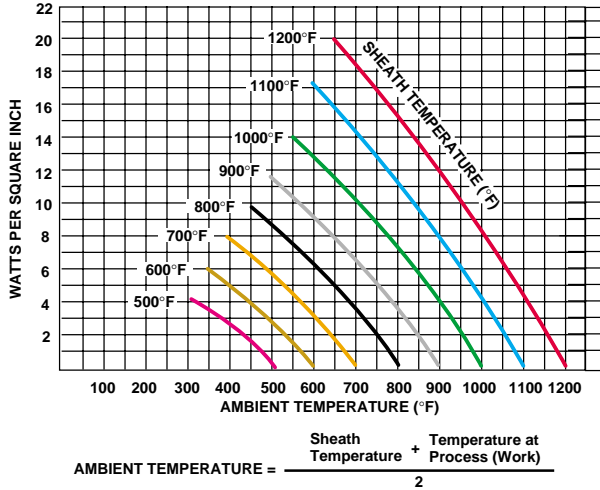

**19T: Allowable Watt Density of HD Strip Heaters to Produce 700°F Sheath Temperatures at Various Ambient Temperatures and Air Velocities<sup>2</sup>**

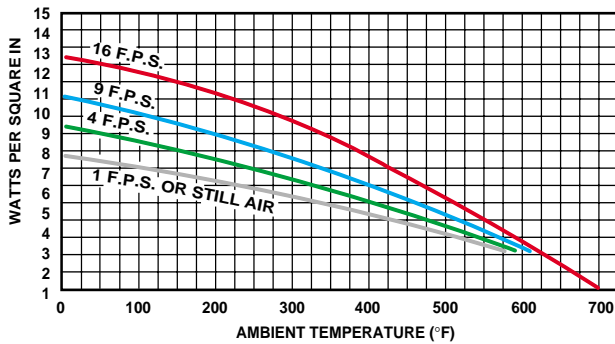

**20T: Allowable Watt Density of HD Strip Heaters to Produce 1000°F Sheath Temperatures at Various Ambient Temperatures and Air Velocities. Use Stainless Steel Sheath Material<sup>2</sup>**

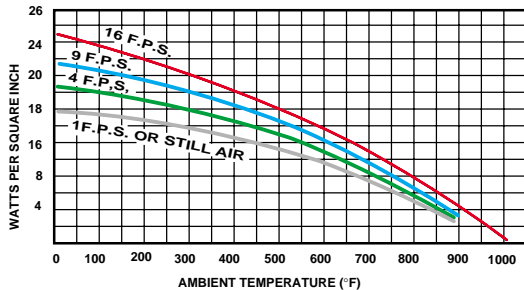

**21T: Allowable Watt Density of Finned HD Strip Heaters to Produce 600° to 700°F Sheath Temperatures at Various Ambient Temperatures and Air Velocities<sup>2</sup>**

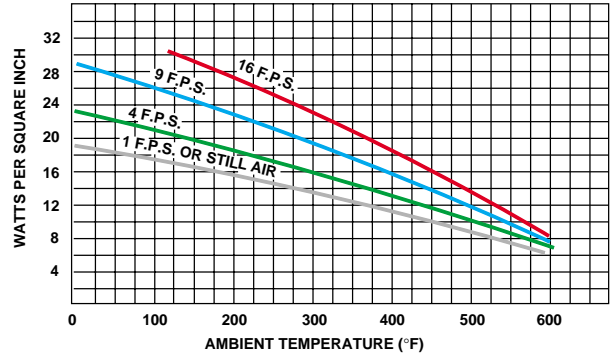

**22T: Allowable Watt Density of Finned HD Strip Heaters to Produce 800° to 900°F Sheath Temperatures at Various Ambient Temperatures and Air Velocities<sup>1,2</sup>**

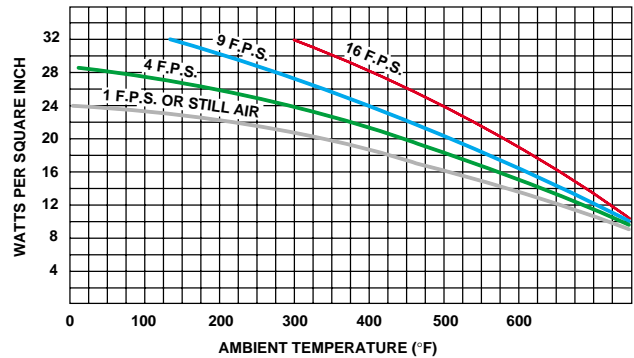

1. Use stainless steel materials (and fins) over 750°F sheath temperatures.  
 2. Where element spacing is close, use 80% of values.

**22A:** Sheath Temperature vs Cold End – .25" Diameter Tubular

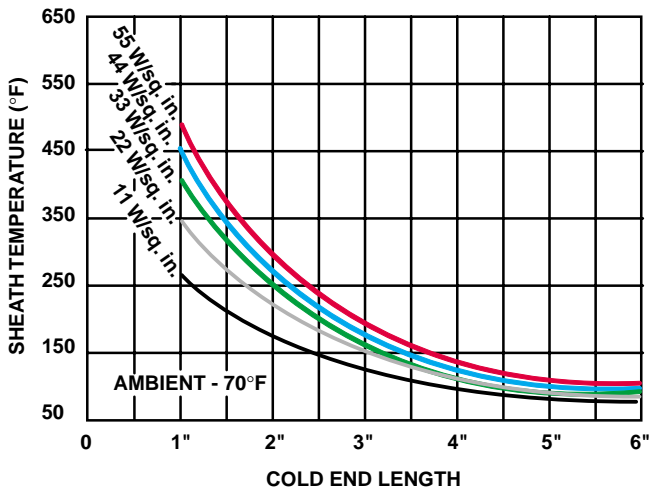

**22D:** Sheath Temperature vs Cold End – .475"/.490" Diameter Tubular

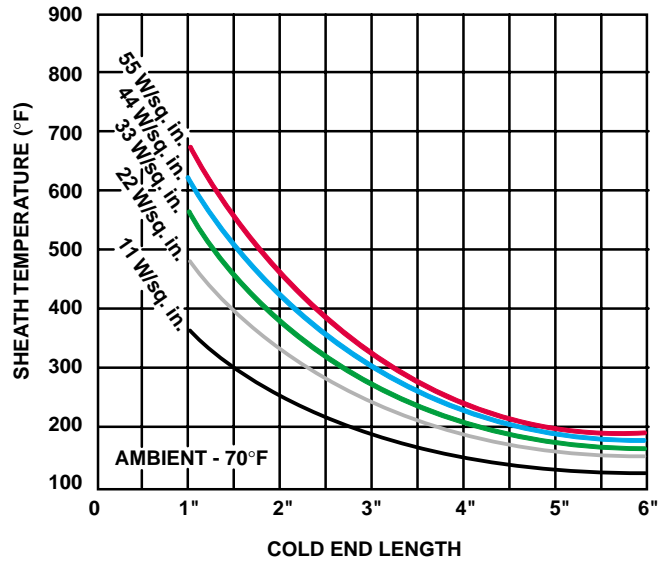

**22B:** Sheath Temperature vs Cold End – .312" Diameter Tubular

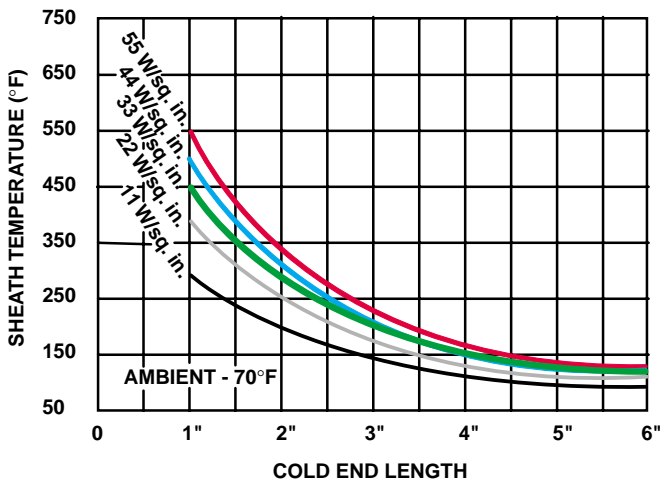

**22E:** Sheath Temperature vs Ambient Temperature in a Vacuum – .430" Diameter Tubular

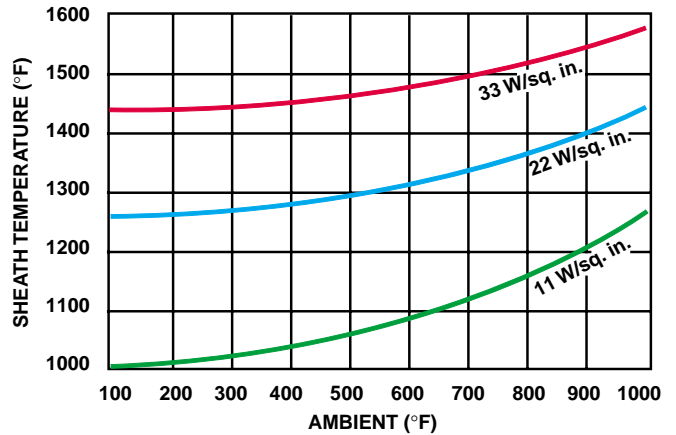

**22C:** Sheath Temperature vs Cold End – .430" Diameter Tubular

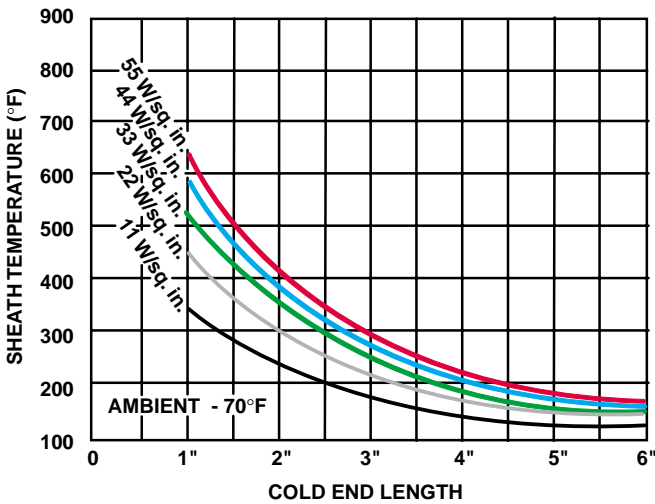

**22F:** Tubular Heater Sheath Temperatures Operating in Different ambient temperatures at various watt densities.

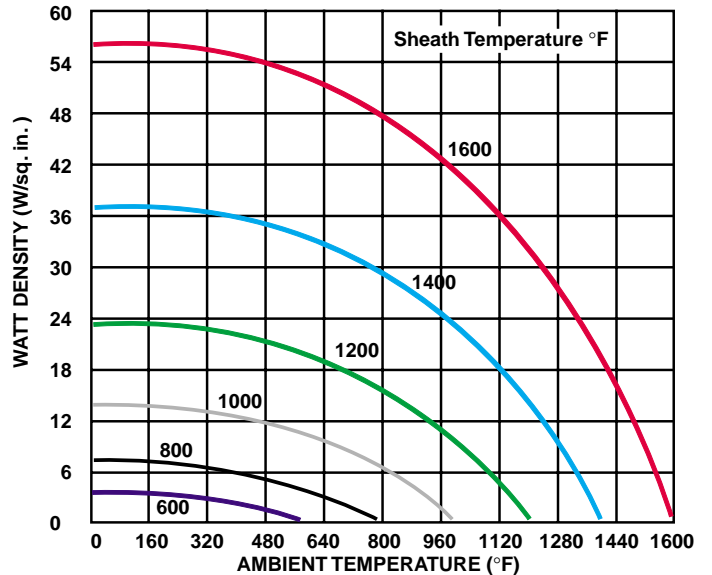

# WATT DENSITY AND OPERATING TEMPERATURE GUIDELINES FOR VARIOUS MATERIALS

**23T:** The information presented is only intended as a guideline. Adjustments may be necessary should variations occur in heat transfer, flow rates and temperatures. The sheath material and watt density selected must be based upon the specific dynamics of the application. See complete **Corrosion Resistance of Sheath Materials (24T)**.

Material To Be Heated	Maximum Operating Temp (°F)	Max. Watt Density (W/sq. in.)	Sheath Material
Acid Solutions (Mild)			
Acetic	180	40	C-20, Quartz
Boric	257	40	Quartz
Carbonic	180	40	
Chromic	180	40	C-20, Quartz
Citric	180	23	316 S.S.
Fatty Acids	150	20	316 S.S.
Lactic	122	10	316 S.S.
Malic	122	10	316 S.S.
Nitric	167	20	Quartz
Phenol—2,4 Disulfonic	180	40	316 S.S.
Phosphoric	180	23	Quartz
Phosphoric (Aerated)	180	23	Stainless Steel
Propionic	180	40	Quartz
Tannic	167/180	23/40	Quartz
Tartaric	180	40	316 S.S.
Acetaldehyde	180	10	Copper
Acetone	130	10	Incoloy
Air	C/F		Incoloy
Alcyl Alcohol	200	10	Copper
Alkaline Solutions	212	40	Steel
Aluminum Acetate	122	10	316 S.S.
Aluminum Potassium Sulfate	212	40	Copper
Ammonia Gas	C/F		Steel
Ammonium Acetate	167	23	Incoloy
Amyl Acetate	240	23	Incoloy
Amyl Alcohol	212	20	Stainless Steel
Aniline	350	23	Stainless Steel
Asphalt	200-500	4-10	Steel
Barium Hydroxide	212	40	316 S.S.
Benzene, liquid	150	10	Copper
Butyl Acetate	225	10	316 S.S.
Calcium Bisulfate	400	20	316 S.S.
Calcium Chloride	200	5-8	Quartz
Carbon Monoxide	—	23	Incoloy
Carbon Tetrachloride	160	23	Incoloy
Caustic Soda 2%	210	48	Incoloy
10%	210	25	Incoloy
75%	180	25	Incoloy
Citrus Juices	185	23	316 S.S.
Degreasing Solution	275	23	Steel
Dextrose	212	20	Stainless Steel
Dyes & Pigments	212	23	Stainless Steel
Electroplating Baths			
Cadmium	180	40	Stainless Steel
Copper	180	40	Quartz
Dilute Cyanide	180	40	316 S.S.
Potassium Cyanide	180	40	Quartz
Rochelle Cyanide	180	40	Stainless Steel
Sodium Cyanide	180	40	Stainless Steel
Ethylene Glycol	300	30	Steel
Formaldehyde	180	10	Stainless Steel
Freon gas	300	2-5	Steel

Material To Be Heated	Maximum Operating Temp (°F)	Max. Watt Density (W/sq. in.)	Sheath Material
Fuel Oils			
Grades 1 & 2 (distillate)	200	23	Steel
Grades 4 & 5 (residual)	200	13	Steel
Grades 6 & bunker C (residual)	160	8	Steel
Gasoline	300	23	Steel
Gelatin: Liquid	150	23	Stainless Steel
Solid	150	5	Stainless Steel
Glycerine	500	10	Incoloy
Glycerol	212	23	Incoloy
Grease: Liquid	—	23	Steel
Solid	—	5	Steel
Hydrazine	212	16	Stainless Steel
Hydrogen	C/F	—	Incoloy
Hydrogen Sulfide	C/F	—	316 S.S.
Linseed Oil	150	50	Steel
Lubrication Oil			
SAE 10	250	23	Steel
SAE 20	250	23	Steel
SAE 30	250	23	Steel
SAE 40	250	13	Steel
SAE 50	250	13	Steel
Magnesium Chloride	212	40	C-20, Quartz
Manganese Sulfate	212	40	Quartz
Methanol gas	C/F	—	Stainless Steel
Methylchloride	180	20	Copper
Mineral Oil	200	23	Steel
	400	16	Steel
Molasses	100	4-5	Stainless Steel
Naphtha	212	10	Steel
Oil Draw Bath	600	23	Steel
Oils (see specific type)	400	24	Steel
Paraffin or Wax (liquid state)	150	16	Steel
Perchloroethylene	200	23	Steel
Potassium Chlorate	212	40	316 S.S.
Potassium Chloride	212	40	316 S.S.
Potassium Hydroxide	160	23	Monel
Soap, liquid	212	20	Stainless Steel
Sodium Acetate	212	40	Steel
Sodium Cyanide	140	40	Stainless Steel
Sodium Hydride	720	28	Incoloy
Sodium Hydroxide	—	See Caustic Soda	—
Sodium Phosphate	212	40	Quartz
Steam, flowing	300	10	Incoloy
	500	5-10	Incoloy
	700	5	Incoloy
Sulfur, Molten	600	10	Incoloy
Toluene	212	23	Steel
Trichlorethylene	150	23	Steel
Turpentine	300	20	Stainless Steel
Vegetable Oil & Shortening	400	30	Stainless Steel
Water (Process)	212	60	S.S., Incoloy

**Properties of Heat Transfer Oils:** Sheath material utilized is typically steel

Material	Maximum Fluid Temperature °F	Maximum Sheath Temperature °F	Maximum w/in. <sup>2</sup>	Density Weight in lbs/cu. ft.	Specific Heat	Flammability °F			Minimum Velocity of Material Through Elements in Ft./Second			
						Flash Point	Fire Point	Auto Ignition	8 w/in. <sup>2</sup>	16 w/in. <sup>2</sup>	23 w/in. <sup>2</sup>	30 w/in. <sup>2</sup>
Caloria HT 43	475	680	12	52.0	0.43	400	—	670	1.5	2.5	3	4
Dowtherm A	725	835	20	66.0	0.38	255	275	1150	.5	1	2	3
Dowtherm J	575	650	20	54.1	0.43	145	155	806	1	2	3	4.5
Dowtherm LF	575	675	20	63.0	0.40	260	280	1020	.7	1.5	2.5	3.5
Dowtherm G	675	775	20	68.6	0.37	305	315	1150	.7	1.5	2.5	3.5
Dowtherm HT	625	700	20	60.6	0.37	—	—	—	1.5	2.5	3.5	5
Marlotherm S	675	695	12	60.8	0.43	374	—	932	1.5	3	5	7
Mobiltherm 603	550	625	20	53.9	0.44	380	—	—	1.5	3	5	7
Multitherm PG-1	565	640	12	54.2	0.45	340	385	690	1	2	3	4
Multitherm IG-2	575	650	20	54.8	0.47	440	500	700	.8	1.7	2.3	3
Syltherm XLT	475	550	12	52.6	0.40	116	130	662	1.5	2.5	4	5
Syltherm 800	725	800	12	58.7	0.38	350	380	725	1.5	3	5	7
Therminol 44	400	475	12	57.8	0.47	405	438	705	1	2	3	4
Therminol 55	560	605	12	55.2	0.46	350	410	675	1.5	2.5	3.5	5
Therminol 59	575	650	20	60.6	0.41	302	335	770	1.5	2.5	3.5	5
Therminol 60	560	655	20	62.6	0.39	310	320	835	1.5	3	5	7
Therminol 75	675	805	20	68.8	0.38	390	440	1000	1	2	3	4
Therminol LT	475	650	20	53.7	0.43	134	150	805	1.5	2.5	4	5
Therminol VP-1	725	800	20	66.7	0.37	255	280	1150	1	2	3	4
UCON 500	475	550	12	64.8	0.47	540	600	750	1	2	3	4

C/F —Consult Factory      NOTE: C-20 designates Carpenter Stainless #20

# CORROSION RESISTANCE OF SHEATH MATERIALS

**24T:** The following is a guideline to select an immersion heater sheath material for direct heating of corrosive materials. Based on known data and experience on the compatibility of standard materials and corrosive environments, the information should only be considered an initial step in the selection process. Other information can come from the manufacturer of the corrosive material and testing. The final selection comes from the end user's knowledge of the process. Variables to consider include:

1. Solution chemistry
2. Possible contamination of the solution from other processes
3. Process temperature
4. Flow rate (velocity) across elements
5. Reducing heater watt density to keep element temperatures as low as possible
6. Accumulating sludge can impede heat transfer from the elements to the process and can accelerate corrosion.
7. The welding or other contact of dissimilar metals could generate galvanic corrosion
8. Provision should be made to periodically inspect the elements to

insure the continuation of the process  
9. See warranty statement pertaining to corrosion

**\*NOTES**

1. This solution involves a mixture of various chemical compounds whose identity and proportions are unknown or subject to change without prior knowledge. Check supplier to confirm choice of sheath materials plus alternate sheath materials that may be used.
2. Caution – Flammable material
3. Chemical composition varies widely. Check supplier for specific recommendations.
4. Direct immersion heaters not practical. Use clamp-on heaters on outside surface.
5. Element watt density should not exceed 20 watts/sq. in.
6. For concentrations greater than 15%, element watt density should not exceed 20 watts/sq. in.
7. See suggested watt density chart.
8. Remove crusts at liquid level.
9. Clean often.
10. Do not exceed 12 watts/sq. in.
11. Passivate stainless steel, Inconel and Incoloy.

SOLUTION	SHEATH MATERIAL														
	IRON-STEEL	CAST IRON	ALUMINUM	COPPER	MONEL-400	304-321, 347, S.S.	316 S.S.	CARPENTER STAINLESS #20	INCOLOY 800	INCONEL 600	TITANIUM	QUARTZ	TEFLON		
Acetic Acid	X	X	C	X	B	C	B	A	C	C	A	A	A	Note 2	
Acetone	X	X	B	A	A	B	B	B	A	A	A	A	A	Note 1	
Alcohol	B	B	B	A	A	B	A	A	A	A	A	A	A	Note 1	
Alcorite						B							A	Note 1, Note 9	
Alkaline Cleaners													X	Note 1	
Alkaline Soaking Cleaners	B													Note 1	
Alodine							A						A	Note 1	
Aluminum Bright Dip								X				A	A	Note 1	
Aluminum Chloride	X	X	X	X	X	X	X	X	X	X	C	A	A	Note 1	
Aluminum Cleaners	C	C	X	X	A	A	A	B	A	A	B	X	A	Note 1	
Aluminum Sulphate	X	X	X	X	X	A	A	A	X	X	A	A	A	Note 1	
Alum	X	X	X	X	X	X	X	B	X	X	X	A	A	Note 1	
Ammonia	X	X	C	X	X	X	X	X	C	B	A	A	A		
Ammonium Bipluoride	X	X	X	X	X	X	X	B	X	X	X	X	A		
Ammonium Chloride	X	X	X	X	C	C	C	C	C	C	A	A	A		
Ammonium Hydroxide	A	A	X	X	A	A	A	A	A	A	A	X	A		
Ammonium Nitrate	A	X	C	X	X	A	A	A	X	X	X	A	A		
Ammonium Persulphate	X	X	X	X	X	C	B	B	C	C	A	A	A		
Ammonium Sulphate	X	X	X	X	B	C	B	B	B	B	A	A	A	Note 2	
Amyl Alcohol	A	B	C	A	B	B	B	B	B	B	A	A	A	Note 2	
Aniline	B	B	B	X	B	A	A	A	B	B	A	A	A		
Anodizing	X	X	X	X	X	X	X	A	X	X	X	A	A		
ARP-28													A	Note 1	
ARP-80 Blackening Salt													A	Note 1	
Arsenic Acid	X	X	X	X	X	C	B	B	X	X	X	A	A	Note 2	
Asphalt	A	A	X	X	X	A	A	A	A	A	A	A	A	Note 2	
Barium Hydroxide	B	B	X	X	B	B	A	A	B	B	X	A	A		
Barium Sulphate	B	B	B	B	B	B	B	B	B	B	A	A	A		
Black Nickel													A	Note 5	
Black Oxide						A							A	Note 5	
Boric Acid	X	X	X	C	C	C	C	C	C	C	A	A	A		
Brass Cyanide						A								Note 1	
Bright Copper-Acid												A		Note 1	
Bright Copper-Cyanide	A					A					A	A		Note 1, Note 5	
Bright Nickel														Note 1	
Bronze Plating	A					A								Note 1	
Butanol	A	A	B	A	A	A	A	A	A	A	A	A	A	Note 2	
Cadmium Black												A		Note 1	
Cadmium Plating						A								Note 1	
Calcium Chlorate	B	B	B	C	B	B	B	B	B	B	B	A	A		
Calcium Chloride	B	B	A	B	B	B	B	B	B	B	A	A	A		
Carbon Dioxide-Dry Gas	X	X	A	A	A	A	A	A	A	A	X	A	X		
Carbon Dioxide-Wet Gas	X	X	A	X	A	A	A	A	A	A	X	A	X		
Carbonic Acid	C	C	B	C	C	B	B	A	B	A	A	A	A		
Carbon Tetrachloride	X	X	X	A	A	A	A	A	A	A	A	A	A		
Castor Oil	A	A	A	A	A	A	A	A	A	A	A	A	A		
Caustic Etch	A	A	X	C	A	A	A	A	A	A	A	X	A	Note 6	
Chlorine Gas-Dry	X	X	X	X	C	C	C	B	C	B	B	A	B		
Chlorine Gas-Wet	X	X	X	X	X	X	X	X	X	X	X	A	X		
Chloroacetic Acid	X	X	X	X	C	X	X	X	C	C	A	A	A		
Chromium Plating	X	X	X	X	X	X	X	X	X	X	A	A	X		
Chromic Acetate												A		Note 1	
Chromic Acid	X	X	X	X	X	X	X	X	X	X	A	A	X		
Chromic Anodizing											A	A		Note 1	

A—Good

B—Fair

C—Depends upon conditions

X—Unsuitable

Blank—Data unavailable

24T (continued): Corrosion Resistance of Sheath Materials

SOLUTION	SHEATH MATERIAL													*NOTES
	IRON-STEEL	CAST IRON	ALUMINUM	COPPER	MONEL-400	304, 321, 347, S.S.	316 S.S.	CARPENTER STAINLESS #20	INCOLOY 800	INCONEL 600	TITANIUM	QUARTZ	TEFLON	
Chromylite Citric Acid Clear Chromate Cobalt Nickel Cobalt Plating Cod Liver Oil	X	X	X	X	B	B	A	A	B	B	A	A A A A	A	Note 1  Note 1 Note 1, Note 6 Note 1
Copper Acid Copper Bright Copper Bright Acid Copper Chloride Copper Cyanide Copper Fluoborate	X A	X A	X X	X X	X C B	X B B	X B B	X B B	X X B	X X B	A	A A A	A A	Note 1 Note 1 Note 1
Copper Nitrate Copper Pyrophosphate Copper Strike Copper Sulphate Creosote Cresylic Acid	X A X A C	X A X A C	X X C C	X C B C	X A A X B B	B A A B B B	B B B A B	B A B B	C C C	X X X B C	A	A A A A	A A	Note 1 Note 1  Note 2 Note 2
Deionized Water Deoxidizer (Etching) Deoxidizer (3AL-13) Dichromic Seal Diethylene Glycol Diversey-DS9333	X B	X A	B	B	B	A	A	A	B	B	A	A A	A	Note 1 Note 1, Non-Chromate  Note 1
Diversey-511 Dur-Nu Electro Cleaner Electro Polishing Electroless Nickel Electroless Tin (Acid)	A				A						A	A A A A		Note 1, Note 5 Note 1, Note 5 Note 1 Note 1 Note 1 Note 1
Electroless Tin (Alkaline) Ether Enthone Acid-80 Ethyl Chloride Ethylene Glycol Fatty Acids	B B A X	B B A X	B A A A	B A B X	B B B B	B A B A	A A B A	A A B A	B B C B	B A C B	A A A A	A A A A	A A	Note 1 Note 2 Note 1 Note 2 Note 5
Ferric Chloride Ferric Nitrate Ferric Sulphate Fluoborate (high speed) Fluorine Gas, Dry Formaldehyde	X X X C X	X X X X X	X X X X B	X X X X B	X X X A B	X B B C A	X B C C A	X A B C A	X X C C B	X X C A B	A A A A A	A A A A C A	A A	Note 1
Formic Acid Freon Fuel Oil-Normal Fuel Oil-Acid Gasolene-Refined Gasolene-Sour	X A A X A C	X A A X A C	B A A X A C	B A A X A C	B A A C X	A A A C B	X A A B A	A A A A A	B A C B X	B A B C X	C	A		Note 2, Note 3, Note 7 Note 2, Note 3, Note 7 Note 2, Note 5 Note 2, Note 3, Note 5
Glycerin, Glycerol Gold Acid Gold-Cyanide Grey Nickel Hot Seal Sodium Dichromate Hydrocarbons-Aliphatic	B A  A	B  A A	A  A A	B  A A	A  A A	A  A A	A  A A	A  A A	A  A A	A  A A	A  A A	A  A A	A  A	Note 1 Note 1 Note 1, Note 5 Note 1 Note 2
Hydrocarbons-Aromatic Hydrochloric Acid Hydrocyanic Acid Hydrofluoric Acid Hydrogen Peroxide Indium	A X X X X	A X X X X	A X B X A	A X X X X	A X B X B	A X B X B	A X B X B	A X B X B	A X B X B	A X B X B	X	A X X X A	A A	Note 2  Note 5 Note 1
Iridite-#4-75, #4-73 #14, #14-2, #14-9, #18-P Iridite #1, #2, #3, #4 C, #4PC&S, #4P-4, #4-80, #4L-1, #4-2, #4-2A, #4-2P, #5P-1, #7, #7-P, #8, #8-P, #8-2, #12-P, #15, #17P, #18P							A					A		Note 1  Note 1

A—Good      B—Fair      C—Depends upon conditions      X—Unsuitable      Blank—Data unavailable

24T (continued): Corrosion Resistance of Sheath Materials

SOLUTION	SHEATH MATERIAL											*NOTES		
	IRON-STEEL	CAST IRON	ALUMINUM	COPPER	MONEL-400	304, 321, 347, S.S.	316 S.S.	CARPENTER STAINLESS #20	INCOLOY 800	INCONEL 600	TITANIUM		QUARTZ	TEFLON
Iridite dyes- #12L-2, #40, #80 Irilac Iron Phosphate Isoprep Deoxidizer #187, #188 Isoprep Acid Aluminum Cleaner #186							A A A					A A	A A	Note 1 Note 1  Note 1 Note 1
Jeta Kerosene Lacquer Solvent Lead Acetate Lead Acid Salts Lime Saturated Water	A A X  B	 A X X B	 A X X X	 A X X X	 A B A A	 A A A A	 A A A A	 A A A A	 A B A B	 A B A A	 A A A A	 A A A X	    	Note 1 Note 2 Note 2  Note 1
Linseed Oil Magnesium Chloride Magnesium Hydroxide Magnesium Nitrate Magnesium Sulfate McDermid #629	A X A B B	A X A B B	B X B B B	B B A B B	B B A B A	A C A B B	A B A B B	A B A B B	B B A B B	B A A X A	 A A A B A	 A A A A A	A	Note 2    Note 1
Mercuric Chloride Mercury Methyl Alcohol Methanol Methyl Bromide Methyl Chloride Methylene Chloride	X A B C X X	X A B C C C	X X C X X C	X X B B A C	X B A B A C	X A B A C C	X A B A C C	X A B A C A	X A B B C C	X B A B C B	A A A A A A	A A A A A A		Note 2
Mineral Oil Muriate Naphtha Nickel Acetate Sea Nickel Chloride Nickel Plate-Bright	A  A  X	A  B  X	A  A  X	A  A  X	A  A  C	A  A  X	A  A  C	A  A  B	A  A  C	A  A  B	A  A  C	A  A  A	A  A  A	Note 1 Note 2 Note 1 Note 1, Note 5 Note 1, Note 5
Nickel Plate-Dull Nickel Plate-Watts Sol. Nickel Sulphate Nickel Copper Strike (Cyanide Free) Nitric Acid	 X  X X	 X  X X	 X  X X	 C  X X	 C  A C	 B  A C	 B  A C	 B  A B	 C  X X	 C  X X	 A  A A	 A  A A	 A  A A	Note 1, Note 5 Note 1, Note 5  Note 1
Nitric Hydrochloric Acid Nitric 6% Phosphoric Acid Nitric Sodium Chromate Nitrobenzene Oakite #67 Oil	X  A A	X  B A	X  B A	X  B A	X  B A	X  B A	X  B A	X  A A	X  B A	X  B A	X  A A	A A A A A	A A A	Note 1 Note 1 Note 2 Note 1 Note 7
Oleic Acid Oxalic Acid Paint Stripper (High Alkaline Type) Paint Stripper (Solvent Type) Paraffin Perchloroethylene	C X A  A	C X A  A	C X A  B	C B A  B	B B A  A	C X A  A	B X A  A	B B A  A	B X A  A	A B B  A	B X A  A	A A A  A	A A	Note 1 Note 1, Note 2 Note 2, Note 7
Petroleum-Crude Phenol Phosphate Phosphate Cleaner Phosphatizing Phosphoric Acid	B B   X	B B   X	A B   X	A    C	A B   C	A C   X	A B A  B	A B A  B	B    C	B    C	A    X	A    A	  X X X A	Note 2, Note 3, Note 7 Note 1, Note 5, Note 9 Note 1, Note 5, Note 9 Note 1, Note 5, Note 9 Note 5, Note 9
Picric Acid Potassium Acid Sulphate Potassium Bichromate Potassium Chloride Potassium Cyanide Potassium Hydrochloric	X  C X C	X  C X X	X  B X X	X  C X X	X  B B C	B  B C B	B  B A B	B  B A B	C  B C B	C  C C B	  A A A X A	  A A A A A	  A A A	Note 1   Note 1
Potassium Hydroxide Potassium Nitrate Potassium Sulphate Reynolds Brightener Rhodium Hydroxide Rochelle Salt Cyanide	X B C  A	X B X  A	X A A  A	X B B  A	B B A  A	C B A  A	C B A  A	C B A  A	C B B  B	B B B  B	C A A A A	 A A A A A	 A A A	Note 1   Note 1

A—Good      B—Fair      C—Depends upon conditions      X—Unsuitable      Blank—Data unavailable

24T (continued): Corrosion Resistance of Sheath Materials

SOLUTION	SHEATH MATERIAL													*NOTES
	IRON-STEEL	CAST IRON	ALUMINUM	COPPER	MONEL-400	304, 321, 347, S.S.	316 S.S.	CARPENTER STAINLESS #20	INCOLOY 800	INCONEL 600	TITANIUM	QUARTZ	TEFLON	
Ruthenium Plating	X	X	X	X	C	X	X	C			A	A	A	Note 1
Silver Bromide	C	C	X	X	B	A	A	A			A	A	A	
Silver Cyanide						A	A		A					Note 1
Silver Lume						C	C	B	C	C	A	A		Note 1
Silver Nitrate	X	X	X	X	X	A	C	B	C	C	A	A		Note 3
Soap Solutions	A	A	X			A	A	A						
Sodium-Liquid Metal	C	X	X	X	B	A			A	A		X		
Sodium Bisulphate	X	X	C		C	X	X	B	B	C	C	A		
Sodium Bromide	B	X	X	B	B	X	B	B	B	B	C	A	A	
Sodium Carbonate	C	C	X	A	B	B	B	B	B	B	A	C	A	
Sodium Chlorate	X	X	B	A	A	B	B	B	B	A	A	A	A	
Sodium Chloride	X	X	X	B	A	X	X	C	B	A	C	A	A	
Sodium Citrate	X	X	X	X		B	B	B				A	A	
Sodium Cyanide	X	B	X	X	X	A	A	A			C	A		
Sodium Dichromate														
(Sodium Bichromate)	A	A	C	X		B	B	B			C	A		
Sodium Hydroxide	C	C	X	X	C	X	C	C	B	B	C	X	A	Note 8, Note 6
Sodium Hypochlorite	X	X	X	X	X	X	X	B	X	X	A	A	A	
Sodium Nitrate	B	B	X	C	B	A	A	A	A	A	A	A		Note 5
Sodium Peroxide	B	A	B	X	B	B								
Sodium Phosphate	B	B	X	B	B	B	B	B	B	B	A	A	A	
Sodium Salicylate	B	C			B	B	B	B	B	B	A	A	A	
Sodium Silicate	B	B	X	B	B	B	B	B	B	B	A	A	A	Note 4
Sodium Sulphate	B	X	A	B	B	X	B	B	B	B	C	A	A	
Sodium Sulphide	X	X	X	X	B	X	C	C	B	C	C	C	A	
Solder Bath	X	B	X	X	X	X	X	X	X	X	X	X	X	
Sodium Stannate	C	C			B	B	B	B	B	B				Note 1
Stanostar														
Stearic Acid	C	C	B	X	X	C	A	B	B	A	A	A	A	
Sugar Solution	A	A	A	A	A	A	A	A	A	A	A	A	A	Note 7
Sulfamate Nickel											A	A	A	Note 1
Sulfuric Acid	X	X	X	X	X	X	X	B	X	X	X	A	A	
Sulfurous Acid	X	X	C	X	X	X	X	A	X	X	A	A	A	
Sulphamic Acid	X	X	X		X	X	X							
Sulphur	X	X	A	X	B	A	A	A	A	A	A	A	A	
Sulphur Chloride	X	X	X	X	C	A	C	C	C	B	A	A	A	
Sulphur Dioxide	C	C	C	C	X	C	B	B	C	C	A	A		
Tannic Acid	X	X	C	X	C	B	B	B	C	C	A	A		
Tin (Molten)			X	X	X	X	X	X		X			X	Note 4
Tin-Nickel Plating												A	A	Note 1
Tin Plating-Alkaline	A					A	A	A	A	A	A			Note 1
Trichloroethane	A	A	A	A	A	A	A	A	A	A	A	A		
Trichlorethylene	A	A	A	B	B	A	A	A	A	A	A	A		
Triethylene Glycol	A	A	A	A	A	A	A	A	A	A	A	A		
Trisodium Phosphate	A	A	X	C	C	C	C	C				X	X	Note 1
Trioxide (Pickle)												A	A	Note 1
Turco 4181 (Alk. Cleaner)							A							Note 1
Turco 4008 (Descaler)							A							Note 1, Note 5
Turco 4338 (Oxidizer)							A							Note 1, Note 7
Turco Ultrasonic Solution							A							Note 1
Ubec											A	A	A	Note 1
Udylite #66											A	A	A	Note 1, Note 5
Unichrome CR-110											A	A	A	Note 1
Unichrome 5RHS											A	A	A	Note 1
Water Deionized	X	X	X	X	A	A	A	A	A	A				Note 11
Water Demineralized	X	X	X	X	A	A	A	A	A	A				Note 11
Water Pure	X	X	X	X	A	A	A	A	A	A				Note 11
Water Potable	X	C	C	B	A	C	B	A	A	A	A	A	A	
Water Sea	X	X		X	A	C	C	A	B	B	A	A	A	
Watt's Nickel Strike												A	A	Note 1
Whiskey				A	A	A	A	A						Note 2
Wood's Nickel Strike												A	A	Note 1
Yellow Dichromate								A						Note 1
Zinc (Mo-ten)			X	X	X	X	X	X	X	X	X		X	
Zinc Chloride	X	X	X	X	B	X	X	B	X	B	B	A	A	
Zinc Plating Acid												A	A	Note 1
Zinc Plating Cyanide	A					A								Note 1
Zinc Phosphate							A						X	Note 1, Note 5
Zincate	A					A								Note 1

A—Good

B—Fair

C—Depends upon conditions

X—Unsuitable

Blank—Data unavailable

# PROCESS INFRARED HEATING

As stated and defined in the Thermal System design section, all heat in every process is transferred by conduction, convection or radiation. Infrared falls into the category of radiation. Often contact of the heat source to the transfer medium or the material being processed is not possible (conduction). The application also might not be practically heated with high-velocity air (convection). In these and many other situations, infrared can be an effective heat transfer method. Infrared is utilized in processes such as:

- Conveyor ovens for drying or curing thin surface films such as paint, lacquer, powder coatings, printing ink or adhesives.
- Heat setting or curing a continuous, fast moving web of uniform thickness material such as textiles.
- Removing surface water or absorbed moisture from materials such as paper, fabrics or chipboard.
- Heating conveyor loads of similar small parts or granular materials.
- Vacuum forming thermoplastic sheet and other processes in the manufacturing of plastics and synthetic materials.
- Localized heating of large parts or assemblies.

Infrared is a form of radiation that falls between visible light and radio waves as shown on the electromagnetic spectrum. Heat is transferred from the source to the work by invisible electromagnetic energy. When the infrared energy reaches the surface to be heated, the molecules vibrate intensely, converting to heat energy. Heat then travels through the product by conduction. Most useful infrared energy for industrial processing results between 2 and 4 microns ( $\mu$ ). A micron is the unit of measurement of infrared wavelengths. ( $1 \mu = 10^{-6} \text{ cm}$ )

Fig. 14: Electromagnetic Spectrum

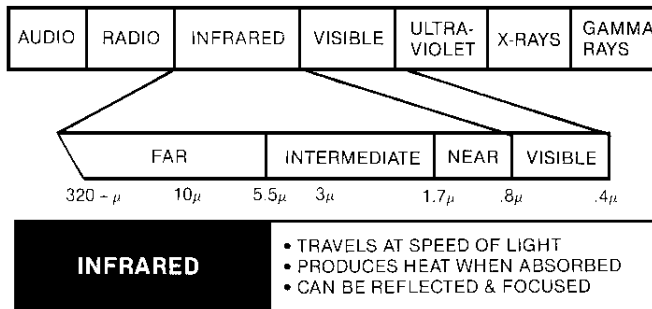

The basic infrared theory is that the intermediate heating of the air between the heat source and the product is not required. Because radiant energy travels at the speed of light, heat transfer is very efficient when the characteristics of the material being heated absorbs infrared well. Also, the energy can be directed into specific patterns by the use of reflectors.

How well a material emits or absorbs infrared is its emissivity factor. The perfect black body is an ideal surface which completely emits or absorbs all radiant energy. The black body's emissivity factor is 1.00. All other surfaces have lower emissivities, and factors less than 1.00. A practical assumption is that a good emitter is also a good absorber. Hence, a polished aluminum surface with an emissivity of .04 would absorb far less radiant energy (everything else being equal) than roofing paper at .91. The energy that isn't absorbed is either reflected or transmitted

25T: Emissivity Factors for Various materials

Solid Materials	Emissivity	
	polished	oxydized
Aluminum	.05	.15
Asphalt		.85
Brass	.09	.6
Brick/Masonry		.83
Carbon		.96
Concrete		.9
Copper	.02	.6
Enamel, white		.92
Flour		.9
Glass		.95
Gold		.02
Gypsum		.9
Ice		.97
Iron, cast	.21	.7
Iron, wrought	.28	.7
Lead	.08	.7
Leather		.95
Limestone		.95
Linoleum		.9
Marble		.9
Meat		.95
Nickel	.06	.9
Paper		.85
Paint		.85
Pitch, hard		.95
Plaster		.79
Porcelain		.92
Rubber		.95
Salt, rock		.95
Sand, dry		.76
Silver	.03	.8
Stainless Steel	.17	.85
Steel	.11	.75
Tin	.18	.6
Wood		.95
Zinc	.03	.5
<b>Liquid Materials</b>		
Mercury		.1
Oil, Machine		.82
Water		.96

Depending upon a materials' emissivity factor, reflective losses can be high. Where the system design allows, built-in reflectors can re-direct these losses back to the material being heated to where almost all energy is absorbed. Long and medium wavelength infrared emitters such as Incoloy sheath tubulars, quartz, and Black Body Ceramic heaters lose little if any energy by being transmitted through a material. Almost without exception, radiant energy is either absorbed or reflected.

Fig. 15: Energy Equation

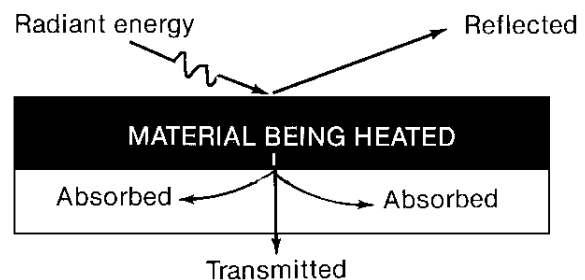

Energy Equation:

$$\text{Energy Absorbed} + \text{Energy Reflected} + \text{Energy Transmitted} = \text{Total Incident Radiation}$$

As the distance from the heat source to the material is increased or decreased, the radiation intensity increases or decreases exponentially. In the initial sampling and testing a distance of 12" for a conveyorized process will

produce uniform radiant distribution. Specific application considerations may require the distance to be adjusted.

Materials are selective as to the wavelength accepted to absorb infrared energy. As can be seen on 38T, PVC will absorb best at 3.5 microns. The wavelength produced by the heat source is dependent upon the source temperature. It is possible then to adjust the source temperature and thus the peak wavelength to match the best spectral absorption rate or wavelength. The formula is:

$$^{\circ}\text{F} = \frac{5215}{\mu} - 459 \quad ^{\circ}\text{C} = \frac{2897}{\mu} - 273$$

Thus, if the element temperature is known and the wavelength is desired:

$$\mu = \frac{5215}{459 + ^{\circ}\text{F}} \quad \mu = \frac{2897}{273 + ^{\circ}\text{C}}$$

By applying the formula to PVC, based upon 3.5 microns being the desired wavelength, 1025°F (550°C) would be the emitter's surface temperature for the best heat transfer to the process. This principle holds true no matter what the construction of the heat source. An Incoloy® tubular heater, the resistance wire of a quartz heater, an FP Flat Panel heater or a Black Body Ceramic Infrared heater operating at 842°F (450°C) would all have the same peak energy wavelength of 4 microns. Other characteristics such as penetration and color sensitivity would also be the same.

Other common methods of temperature control in infrared processes is by varying the voltage input to the elements or adjusting the amount of on-time versus off-time of the elements. These are open-loop control systems and usually require the constant attention of an operator. A closed loop control system would consist of infrared sensors or thermocouples attached or integral to the heat source, that would monitor the temperature of the process or heater, signal a control which in turn would signal an output device to deliver current (or turn off) the heat source. For complete information, see each respective catalog section, the Thermal System Design section or consult **OGDEN**.

**OGDEN** offers a number of choices of heating elements for infrared applications. The advantages, limitations and adaptability of each will determine which is most suitable. For instance, the emissivity/conversion ratio of an Incoloy® sheath tubular heater is about 55%, a quartz heater's is 60%, an FP Flat Panel's is about 80% and the Black Body Ceramic's is over 90%. This indicates that close to all of the infrared energy produced by the ceramic heater will be absorbed by the process. This type of efficiency may be the most important consideration. But the process may require a heat source with a quick response time. The quartz heater will likely be chosen, or an expensive retraction system may be necessary should a line stoppage occur. The Incoloy® sheath tubular heater could be the best selection because of its ruggedness and ability to be formed to suit spacing or confinement requirements. An FP Flat Panel heater may be selected because of the wide area coverage.

Although much technical information is available in this and other sources, trial and pilot testing are often necessary to establish if a process is suitable for infrared. The wattage required, watt density, process time cycle, distance from the heat source to the material and how well the material absorbs infrared can perhaps only be determined by this method. Should any uncertainty exist, contact **OGDEN**. The information necessary may already be on file, because **OGDEN** has successfully solved scores of infrared heating problems.

## SPECTRAL ABSORPTION OF VARIOUS MATERIALS

### 26T: Water

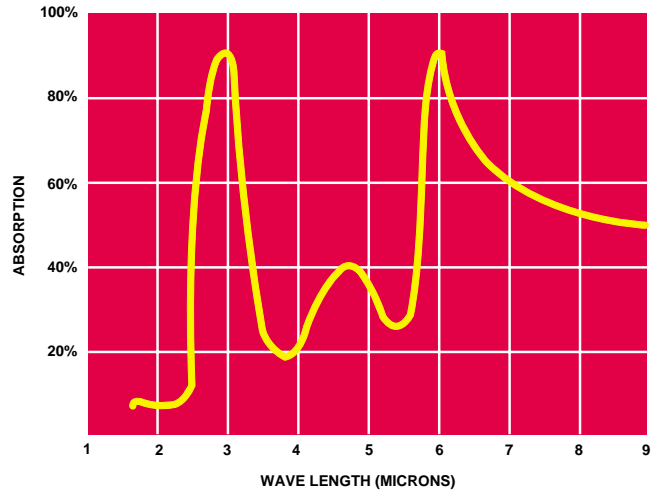

### 27T: Aluminum

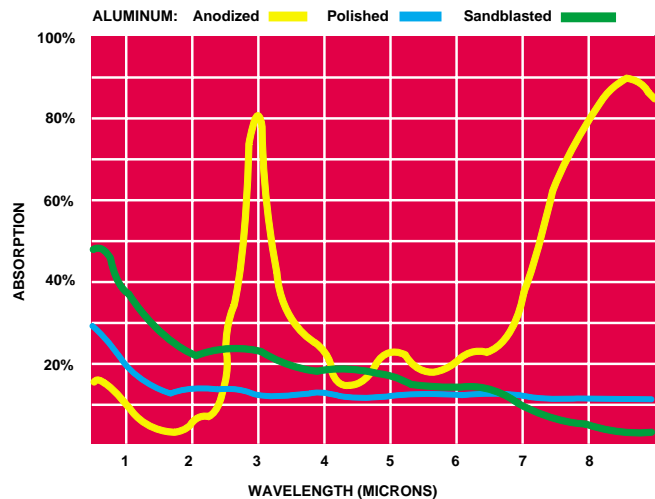

### 28T: Pure Linen, Cotton and Cellulose Wood

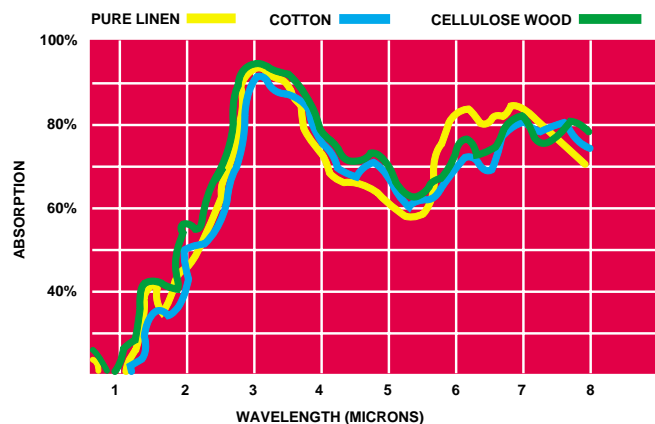

**29T: Paper and Metal Oxide**



**32T: Stucco, Pastebord and Concrete**

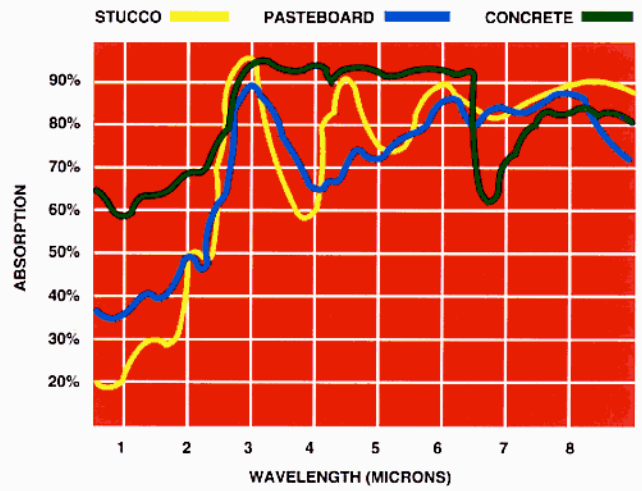

**30T: Silk: Natural and Synthetic**

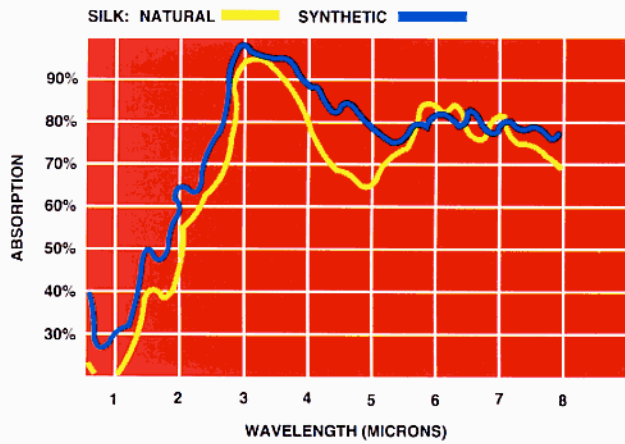

**33T: Roof Tile, White Flagstone and White Fire Clay**

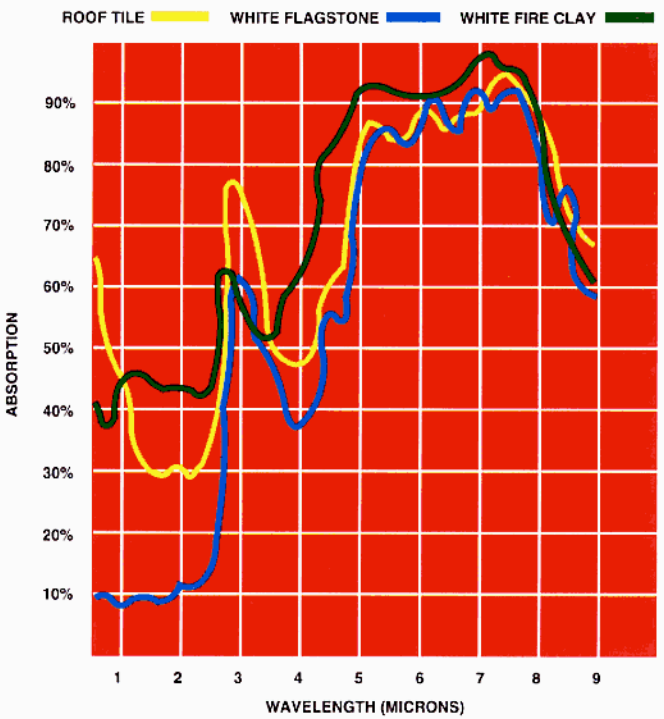

**31T: Magnesium Oxide, Fine Plaster and Cork**

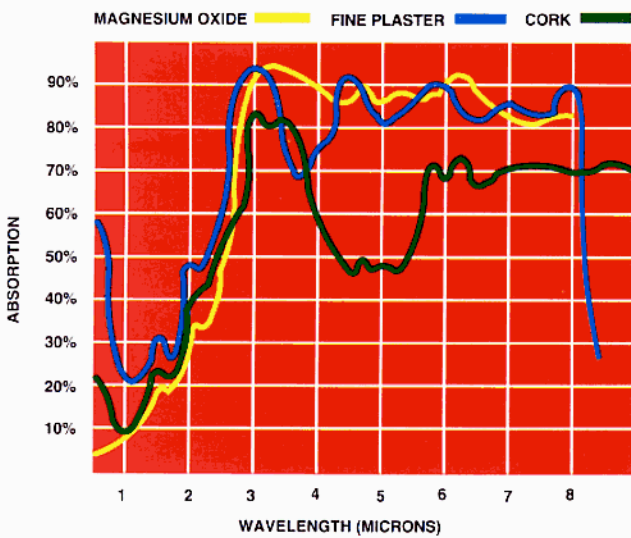

**34T: Porcelain: Glazed and Unglazed**

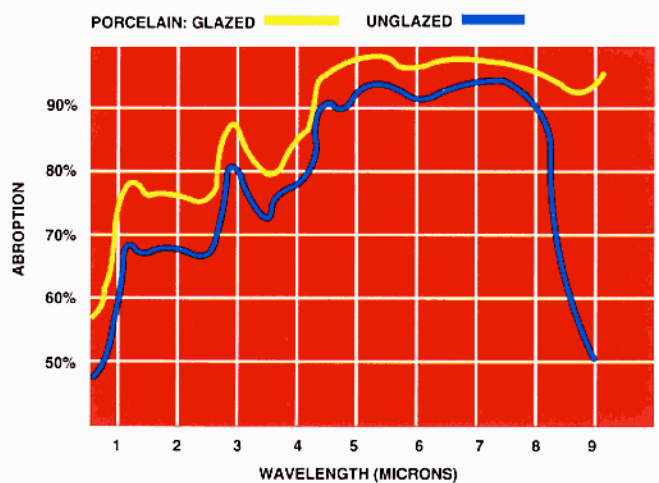

### 35T: Glass: Milk, Crystal and Flint

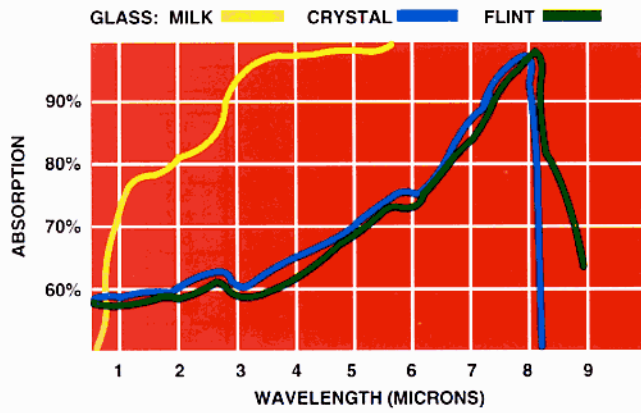

### 39T: Polyethylene

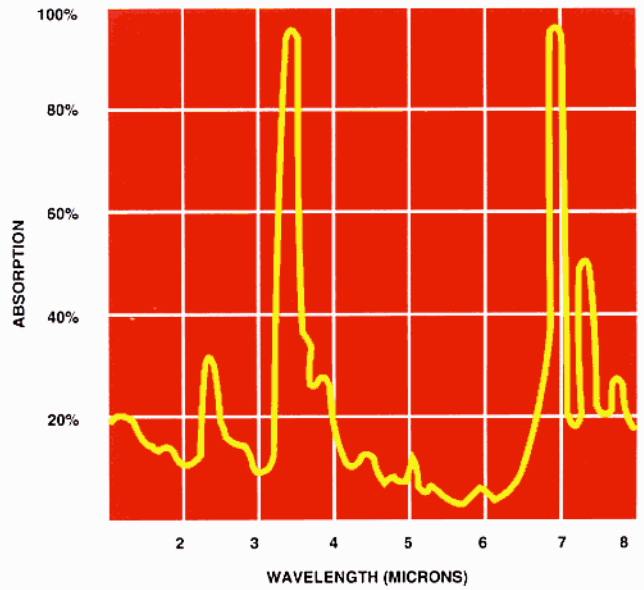

### 36T: Graphite, Carbon Rod and Roofing Felt

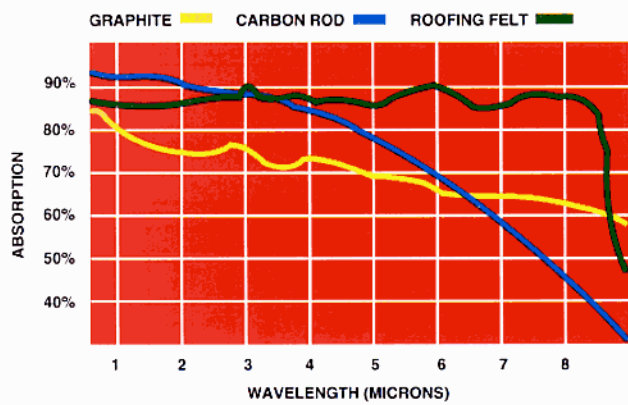

### 40T: Plexiglass

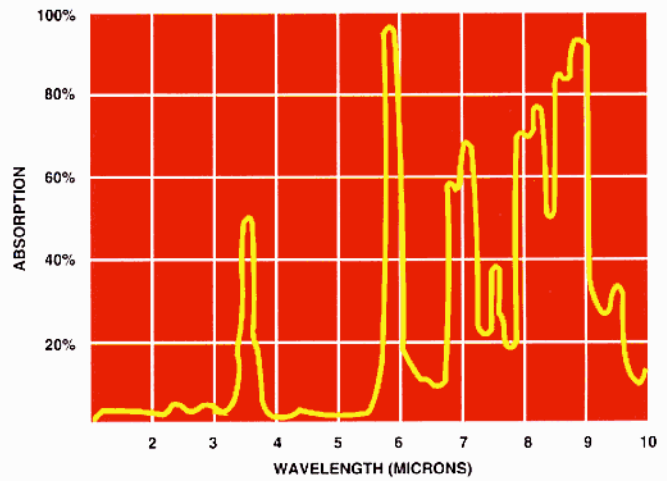

### 37T: Rubber and Linoleum

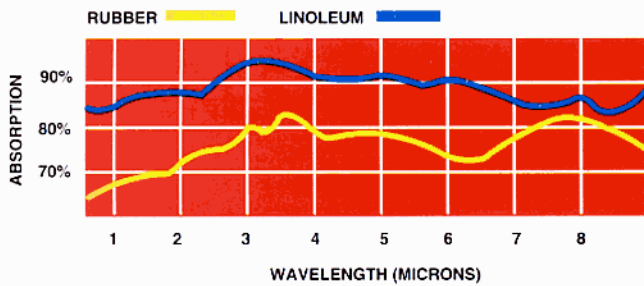

### 41T: Polystyrene

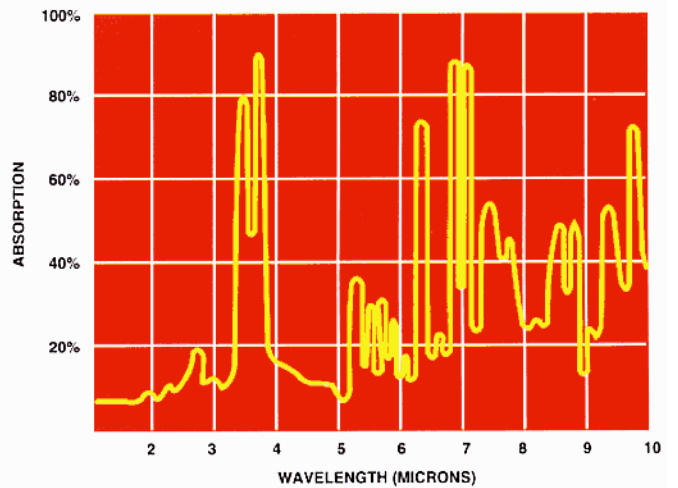

### 38T: PVC

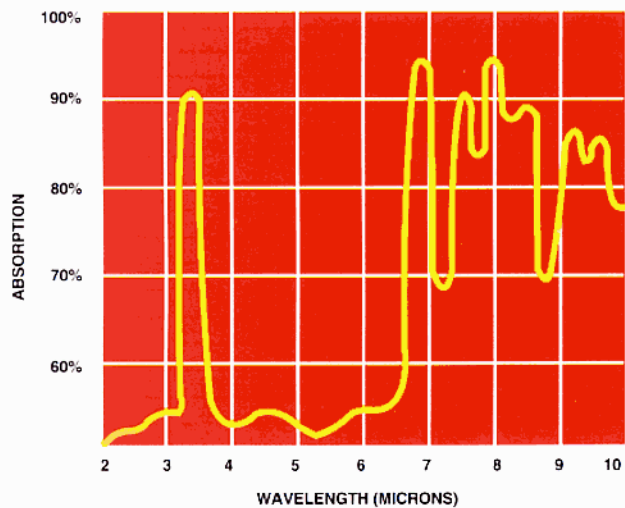

# Radiation / Temperature Comparison Chart

Revision 1.0 16/NOV/99

Temp (°F)	Temp (K)	Peak Wave-length ( $\mu\text{m}$ )	Flux ( watts / in <sup>2</sup> )	Color
900	755	3.83	11.91	
1000	810	3.57	15.82	
1100	866	3.34	20.62	
1200	922	3.14	26.44	
1300	978	2.96	33.41	
1400	1033	2.80	41.68	
1500	1089	2.66	51.39	
1600	1144	2.53	62.71	
1700	2000	2.41	75.81	
1800	1255	2.30	90.85	
1900	1311	2.21	108.04	
2000	1366	2.12	127.55	
2100	1422	2.04	149.59	
2200	1478	1.96	174.37	
2300	1533	1.89	202.11	
2400	1589	1.82	233.04	
2500	1644	1.76	267.38	
2600	1700	1.70	305.39	
2700	1755	1.65	347.32	
2800	1810	1.60	393.42	

# QUICK ESTIMATES FOR WATTAGE REQUIREMENTS

## 42T: To Heat Steel

Weight in lbs.	Temperature Rise (°F)						
	50°	100°	200°	300°	400°	500°	600°
25	.06	.12	.25	.37	.50	.65	.75
50	.12	.25	.50	.75	1.00	1.25	1.50
100	.25	.50	1.00	1.50	2.00	2.50	3.00
150	.37	.75	1.50	2.25	3.00	3.75	4.50
200	.50	1.00	2.00	3.00	4.00	5.00	6.00
250	.65	1.25	2.50	3.75	5.00	6.25	7.50
300	.75	1.50	3.00	4.50	6.00	7.50	9.00
400	1.00	2.00	4.00	6.00	8.00	10.00	12.00
500	1.25	2.50	5.00	7.50	10.00	12.50	15.00
600	1.50	3.00	6.00	9.00	12.00	15.00	18.00
700	1.75	3.50	7.00	10.50	14.00	17.50	21.00
800	2.00	4.00	8.00	12.00	16.00	20.00	24.00
900	2.25	4.50	9.00	13.50	18.00	22.50	27.00
1000	2.50	5.00	10.00	15.00	20.00	25.00	30.00

kw to heat in 1 hour

## 43T: To Heat Air

Cu.ft./minute (scfm)	Temperature Rise (°F)										
	50°	100°	150°	200°	250°	300°	350°	400°	450°	500°	600°
100	1.7	3.3	5	6.7	8.3	10.0	11.7	13.3	15.0	16.7	20.0
200	3.3	6.7	10.0	13.3	16.7	20.0	23.3	26.7	30.0	33.3	40.0
300	5.0	10.0	15.0	20.0	25.0	30.0	35.0	40.0	45.0	50.0	60.0
400	6.7	13.3	20.0	26.7	33.3	40.0	46.7	53.3	60.0	66.7	80.0
500	8.3	16.7	25.0	33.3	41.7	50.0	58.3	66.7	75.0	83.3	100.0
600	10.0	20.0	30.0	40.0	50.0	60.0	70.0	80.0	90.0	100.0	120.0
700	11.7	23.3	35	46.7	58.3	70.0	81.7	93.3	105.0	116.7	140.0
800	13.3	26.7	40	53.3	66.7	80.0	93.3	106.7	120.0	133.3	160.0
900	15.0	30.0	45.0	60.0	75.0	90.0	105.0	120.0	135.0	150.0	180.0
1,000	16.7	33.3	50	66.7	83.3	100.0	116.7	133.3	150.0	166.7	200.0
1,100	18.3	36.7	55	73.3	91.7	110.0	128.3	146.7	165.0	183.3	220.0
1,200	20	40	60	80.0	100.0	120.0	140.0	160.0	180.0	200.0	240.0

kw

Use the maximum anticipated airflow. Chart 35T and below equations assume insulated duct (negligible heat loss), 70°F inlet air and 14 psia.

### Quick estimates for other volumes

For Air:

$$kw = \frac{\text{scfm} \times \text{Temperature Rise (°F)}}{3000}$$

\*Measured at normal temperature and pressure.

For Compressed Air:

$$kw = \frac{\text{scfm}^{**} \times \text{Density}^{**} \times \text{Temperature Rise (°F)}}{228}$$

\*\*Measured at heater system inlet temperature and pressure.

## 44T: To Heat Water

Cubic feet	Gallons	Temperature Rise (°F)						
		20°	40°	60°	80°	100°	120°	140°
.66	5	0.3	0.5	0.8	1.1	1.3	1.6	1.9
1.3	10	0.5	1.1	1.6	2.1	2.7	3.2	3.7
2.0	13	0.8	1.6	2.4	3.2	4	4.8	5.6
2.7	20	1.1	2.2	3.2	4.3	5.3	6.4	7.5
3.3	25	1.3	2.7	4	5.3	6.7	8	9.3
4.0	30	1.6	3.2	4.8	6.4	8	9.6	12
5.3	40	2.1	4	6.4	8.5	11	13	15
6.7	50	2.7	5.4	8	10.7	13	16	19
8.0	60	3.3	6.4	9.6	12.8	16	19	22
9.4	70	3.7	7.5	11.2	15	19	22	26
10.7	80	4.3	8.5	13	17	21	26	30
12.0	90	5	10	14.5	19	24	29	34
13.4	100	5.5	11	16	21	27	32	37
16.7	125	7	13	20	27	33	40	47
20.0	150	8	16	24	32	40	48	56

kw to heat in 1 hour

### Quick estimates for other volumes

$$kw = \frac{\text{gal./hr.} \times 8.34 \times \text{Temperature Rise (°F)}}{3412}$$

$$\text{gal./hr.} = \frac{kw \times 3412}{8.34 \times \text{Temperature Rise (°F)}}$$

## 45T: To Heat Oil

Cubic feet	Gallons	Temperature Rise (°F)					
		50°	100°	200°	300°	400°	500°
.5	3.74	.3	.5	1	2	2	3
1	7.48	.5	1	2	3	4	6
2	14.96	1	1	2	4	6	11
3	22.25	2	3	6	9	12	16
4	29.9	2	4	8	12	16	22
5	37.4	3	4	9	15	20	25
10	74.8	5	9	18	29	40	52
15	112.5	7	14	28	44	60	77
20	149.6	9	18	37	58	80	102
25	187	11	22	46	72	100	127
30	222.5	13	27	56	86	120	151
35	252	16	31	65	100	139	176
40	299	18	36	74	115	158	201
45	336.5	20	40	84	129	178	226
50	374	22	45	93	144	197	252

kw to heat in 1 hour

Add 5% for uninsulated tanks.

### Quick estimates for other volumes

$$kw = \frac{\text{Gallons} \times \text{Temperature Rise (°F)}}{800 \times \text{Process Start-up Time (hrs.)}}$$

# DETERMINING WATTAGE REQUIREMENTS FOR ENCLOSURE HEATERS

TEMPERATURE RISE FROM MINIMUM EXPECTED AMBIENT TEMPERATURE TO DESIRED ENCLOSURE TEMPERATURE (°F)															
Enclosure Surface Area—Square Feet	20		40		60		80		100		120		140		
	50	670	160	1340	320	2010	480	2680	640	3350	800	4020	960	4690	1120
	40	540	130	1075	260	1610	385	2145	515	2680	640	3220	770	3755	900
	30	405	100	805	195	1210	290	1610	385	2010	480	2415	580	2815	675
	25	335	80	670	160	1005	240	1340	320	1675	400	2010	480	2345	560
	20	270	65	540	130	805	195	1075	260	1340	320	1610	385	1880	450
	15	205	50	405	100	605	145	805	195	1005	240	1210	290	1410	340
	10	135	35	270	65	405	100	540	130	670	160	805	195	940	225
	9	120	30	245	60	365	90	485	115	605	145	725	175	845	205
	7.5	100	25	200	50	300	75	400	100	500	125	600	150	700	175
	6	80	20	160	40	245	60	325	80	405	100	485	115	565	135
	5	70	20	135	35	205	50	270	65	335	80	405	100	470	115
	4	55	15	110	30	160	55	215	55	270	65	320	80	375	90
	3	40	10	80	20	120	30	160	40	200	50	240	60	280	70
	2	30	10	55	15	90	20	110	30	135	35	165	40	190	45

Required wattage — Double above values in areas with extreme wind factors.  
 uninsulated cabinet   
 insulated cabinet

Match above values from chart to a standard Enclosure Heater. Use multiple heaters where necessary.

# KW REQUIREMENTS FOR MAINTAINING TANK TEMPERATURES AGAINST HEAT LOSSES

To use graph, assume a requirement for maintaining a fluid temperature of 250°F in an ambient of 30°F in a tank 12' diameter by 20' long. Chart is based upon still air.

**A.** Connect 12' on scale 2 with 20' on scale 6 (line A). The intersection of this line with scale 4 is the surface area of the cylindrical portion of the tank (approximately 800 sq. ft.). The intersection of line A with scale 3 is the tank volume (approximately 17,000 gallons).

**B.** Draw horizontal line B to scale 1 to determine the surface area of the tank ends (approximately 225 sq. ft.).

**C.** Adding A and B is the total surface area of the tank (1,025 sq. ft.). Connect 1,025 on scale 4 and 220°F (250-30°F) on scale 7 with line C. The kw required is where line C intersects scale 5.

Insulated tank = 35kw

Uninsulated tank = 250kw

See wind velocity correction factor chart below.

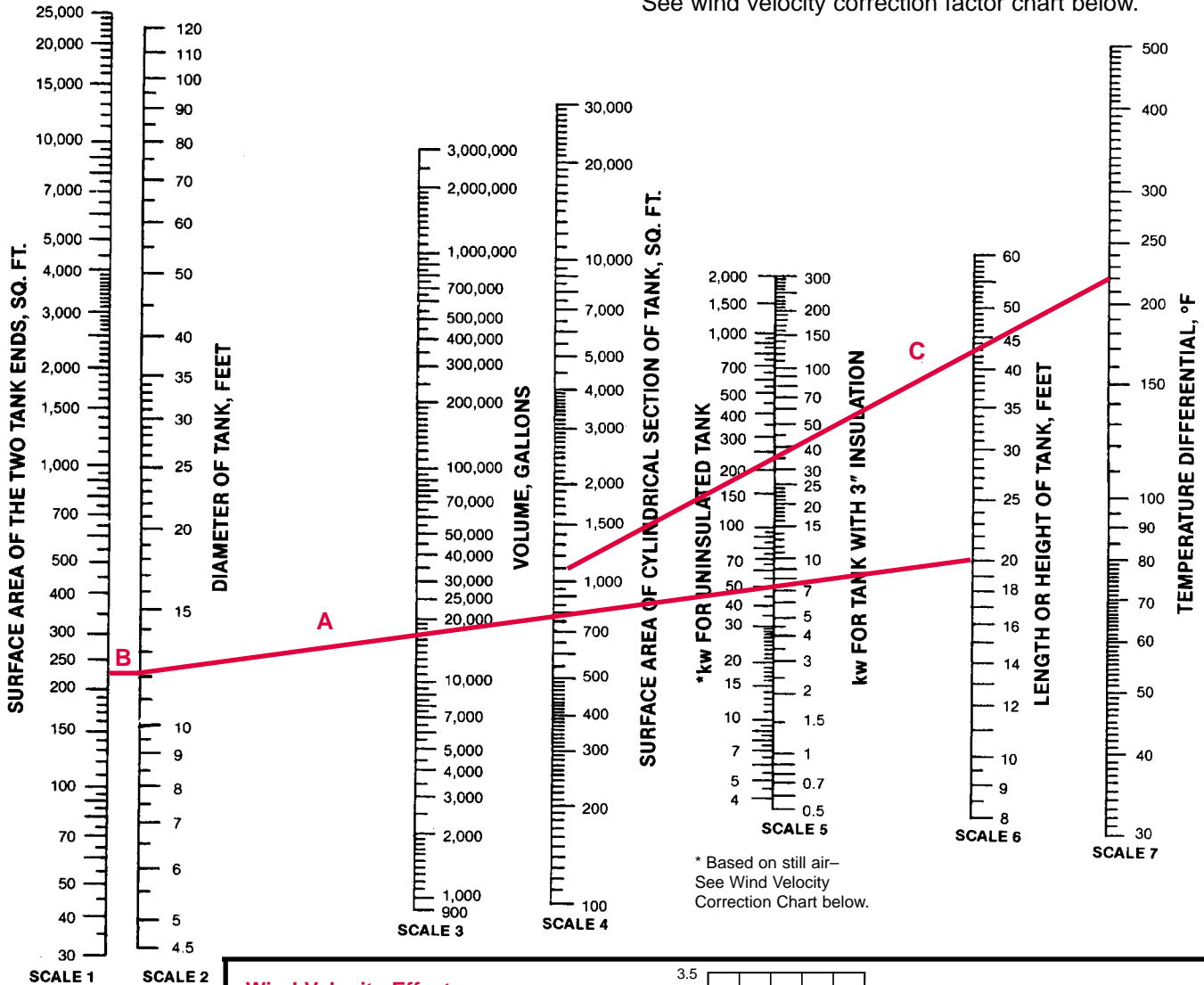

\* Based on still air—  
See Wind Velocity  
Correction Chart below.

## Wind Velocity Effects On exposed, Bare and Insulated Surfaces

1. Determine surface heat losses at still air conditions as per calculation or chart above.
2. Multiply result by wind correction factor from above for total heat loss.

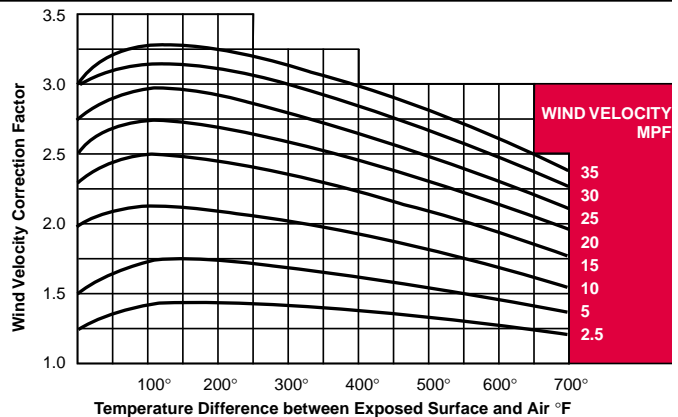

# PROCESS HEATING APPLICATION EXAMPLES

## EXAMPLE 1: HEATING LIQUID IN A TANK

**Description:** An open steel tank, 3 ft. wide, 4 ft. long, 3 ft. deep and weighing 350lb., is filled with water to within 9 inches of the top. Bottom and sides have 4 inches of insulation. Water is to be heated from 50°F to 175°F within 1 hour and, from then on, approximately 12 gallons per hour will be drawn off and replaced.

### Calculation of wattage required:

#### Considerations:

Beginning to final temperature: 50–175°F

Time available for Process Start-Up: 1 hour

Process cycle period: 1 hour

Weight and thermal properties of all materials:

Specific heat of steel: 0.12 Btu/lb./°F

Specific heat of water: 1.0 Btu/lb./°F

Density of water: 62.5 lb./cu.ft. or 8.3 lb./gal.

Weight of water in tank: (3 x 4 x 2.25) cu.ft.

x 62.5 lb./cu.ft. = 1688 lb.

Weight of additional water added during process:

12 gal./hr. x 8.34 lb./gal. = 100 lb.

Weight of tank: 350 lb.

Exposed surface areas and heat losses:

Amount of insulation: 4"

Water surface area: 12 sq.ft.

Tank vertical surface area: 42 sq.ft.

Tank bottom surface area: 12 sq.ft.

From graph 4T, heat losses from the water surface: At 175°F—750 watts/sq.ft.

From graph 1T, heat losses from the insulated surfaces:

At 175°F—8 watts/sq.ft. (bottom surface — 4 watts/sq.ft.)

### STEP 1: Wattage Required for Process Start-Up

$$Q_{ha} + Q_{ls} + CF = \text{kwh}$$

$$\frac{\text{kwh}}{\text{Hours allowed for process start-up}} = \text{kw}$$

#### A. $Q_{ha}$

$$\frac{350\text{lb.} \times 0.12 \text{ Btu/lb./}^\circ\text{F} \times (175-50)^\circ\text{F}}{3412 \text{ Btu/kwh}} = 1.54\text{kwh}$$

+

$$\frac{1688 \text{ lb.} \times 1.0 \text{ Btu/lb./}^\circ\text{F} \times (175-50)^\circ\text{F}}{3412 \text{ Btu/kwh}} = 61.84\text{kwh}$$

+

$$\text{Heat of fusion or vaporization} = \text{NONE}$$

$$= \underline{63.38\text{kwh}}$$

#### B. $Q_{ls}$

$$\frac{12 \text{ sq.ft.} \times 750 \text{ w/sq. ft.} \times 1 \text{ hr.} \times \frac{1}{2}}{1000 \text{ w/kw}} = 4.5\text{kwh}$$

+

$$\frac{42 \text{ sq.ft.} \times 8 \text{ w/sq. ft.} \times 1 \text{ hr.} \times \frac{1}{2}}{1000 \text{ w/kw}} = 0.17\text{kwh}$$

+

$$\frac{12 \text{ sq.ft.} \times 4 \text{ w/sq. ft.} \times 1 \text{ hr.} \times \frac{1}{2}}{1000 \text{ w/kw}} = 0.02\text{kwh}$$

$$= \underline{4.69\text{kwh}}$$

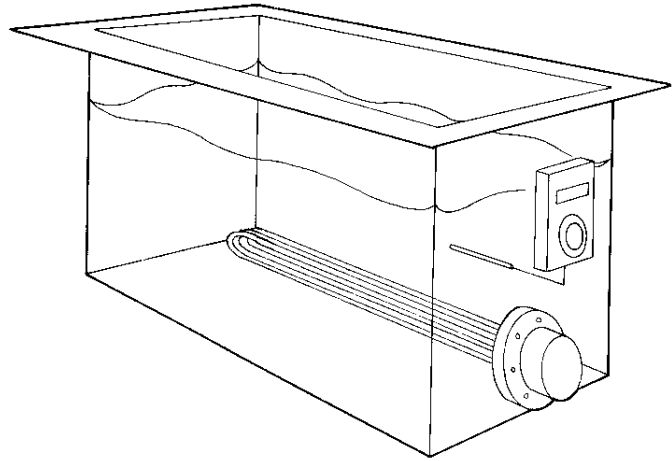

#### C. CF

$$20\% (63.38 + 4.69) = \underline{13.61\text{kwh}}$$

### Wattage Required for Process Start-up:

$$\frac{63.38 + 4.69 + 13.61}{1 \text{ hour}} = \underline{81.68\text{kwh}}$$

### STEP 2: Wattage Required for Process Operation

$$Q_{ha2} + Q_{ls2} + CF = \text{kw}$$

#### D. $Q_{ha2}$

$$\frac{100 \text{ lb.} \times 1.0 \text{ Btu/lb./}^\circ\text{F} \times (175-50)^\circ\text{F}}{3412 \text{ Btu/kwh}} = 3.66\text{kwh}$$

$$\text{Heat of fusion or vaporization} = \text{NONE}$$

$$= \underline{3.66\text{kwh}}$$

#### E. $Q_{ls2}$

$$\frac{\text{Loss from water surface: } 12 \text{ sq.ft.} \times 750\text{w/sq.ft.}}{1000\text{w/kw}} = 9.0\text{kwh}$$

+

$$\frac{\text{Loss from tank vertical surface: } 42\text{sq.ft.} \times 8\text{w/sq.ft.}}{1000\text{w/kw}} = 0.34\text{kwh}$$

+

$$\frac{\text{Loss from tank bottom surface: } 12\text{sq.ft.} \times 4\text{w/sq.ft.}}{1000\text{w/kw}} = 0.05\text{kwh}$$

$$= \underline{9.39\text{kwh}}$$

#### F. CF

$$20\%(3.66 + 9.39) = \underline{2.61\text{kwh}}$$

### Wattage Required for Process Operation:

$$3.66 + 9.39 + 2.61 = \underline{15.66\text{kw}}$$

In this application, with a significant difference between the wattage necessary for start-up versus operation, it is recommended to lengthen the time to initially bring the process to the required temperature. By allowing 7 hours for initial heat-up, the wattage required would drop to 18.36 kw. The time variable in  $Q_{ls}$  would be changed to 7 hrs. and the averaging figure to  $\frac{1}{2}$ . However, during start-up, by placing a cover with 4" insulation over the top

surface, 16 kw would bring the process to temperature in less than 4 hours.

It is necessary to know the condition of the water. If the water is reasonably clean, a copper sheath immersion heater would be adequate, because corrosion of the elements would not be a consideration. As heat is transferred well from the element in the direct immersion heating of water, a watt density up to 60 watts per square inch would be acceptable. If any doubt exists about the process conditions, more research would be necessary.

As this process would not seem to require accurate temperature control, a D1 thermostat would most likely be adequate. Accuracy improvement would be accomplished with electronic controls such as the ETR-404. Careful design of the thermal system would lead to satisfactory process results.

## EXAMPLE 2: CHANGING THE STATE OF A MATERIAL

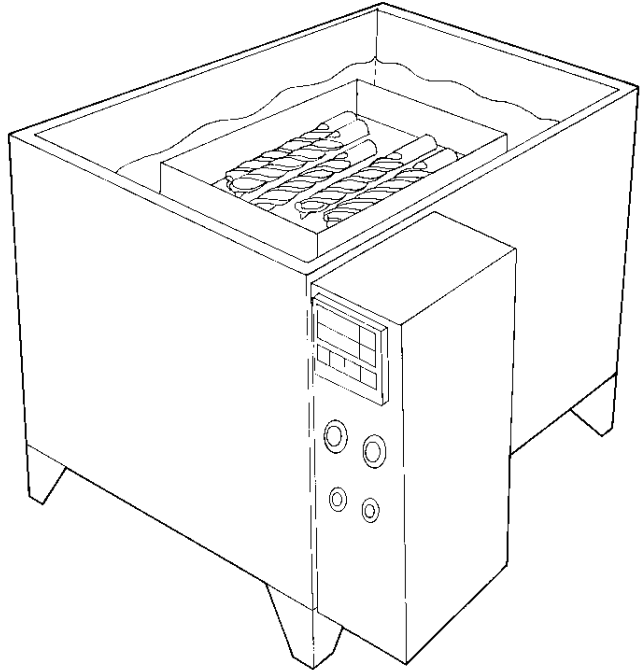

**Description:** An open, uninsulated tank, 1½ ft. wide, 2 ft. long, 1½ ft. deep and weighing 140 lbs., will contain 168 lbs. of paraffin. The manufacturer of steel drills must apply a coating of paraffin as protection prior to shipping. The paraffin needs to be heated from 70–150°F in 3 hours. The steel drills, each weighing .157 lb., are to be placed in a 5 lb. rack and dipped in the melted paraffin. 100 drills will be processed each cycle, 1500 per hour. Each cycle is 4 minutes. 20 additional pounds of paraffin will be required each hour.

### Calculation of wattage required:

#### Considerations:

Beginning to final temperature: 70–150°F  
Time available for process start-up: 3 hours  
Process cycle period: 1 hour  
Weight and thermal properties of all materials:  
Specific heat of steel: 0.12 Btu/lb./°F  
Specific heat of solid paraffin:  
0.70 Btu/lb./°F  
Melting point of paraffin: 133°F  
Heat of fusion of paraffin: 63 Btu/lb.  
Specific heat of melted paraffin:  
0.71 Btu/lb./°F  
Weight of tank: 140 lbs  
Weight of rack: 5 lbs. each (75 lbs. total for  
15 cycles/hour)  
Weight of drills: .157 lb. each—1500/hr.  
(235.5 lbs. total/hr.)  
Weight of paraffin: 168 lbs.  
Weight of paraffin added during process: 20 lbs.  
Exposed surface areas and heat losses:  
Amount of insulation: none  
Paraffin surface area: 3 sq. ft.  
Tank vertical surface area: 10.5 sq. ft.  
Tank bottom surface area: 3 sq. ft.  
From graph 3T, heat losses from paraffin surface:  
At 150°F—70 watts/sq. ft.  
From graph 1T, heat losses from uninsulated tank  
surface: At 150°F—55 watts/sq. ft.  
(bottom surface—27 watts/sq.ft.)

### STEP 1: Wattage Required for Process Start-Up

$$\frac{Q_{ha} + Q_{ls} + CF}{\text{kwh}} = \text{kwh}$$

$$\frac{\text{Hours allowed for process start-up}}{\text{kwh}} = \text{kwh}$$

#### A. Q<sub>ha</sub>

$$\frac{140 \text{ lb.} \times 0.12 \text{ Btu/lb.}^\circ\text{F} \times (150-70)^\circ\text{F}}{3412 \text{ Btu/kwh}} = 0.39\text{kwh}$$

$$\frac{168 \text{ lb.} \times 0.70 \text{ Btu/lb.}^\circ\text{F} \times (133-70)^\circ\text{F}}{3412 \text{ Btu/kwh}} = 2.17\text{kwh}$$

$$\frac{168 \text{ lb.} \times 0.71 \text{ Btu/lb.}^\circ\text{F} \times (150-133)^\circ\text{F}}{3412 \text{ Btu/kwh}} = 0.59\text{kwh}$$

$$\frac{\text{Heat of fusion to melt paraffin: } 168 \text{ lb.} \times 63 \text{ Btu/lb.}}{3412 \text{ Btu/kwh}} = 3.10\text{kwh}$$

$$= \underline{\underline{6.25\text{kwh}}}$$

#### B. Q<sub>ls</sub>

$$\frac{3 \text{ sq.ft.} \times 70 \text{ w/sq.ft.} \times 3 \text{ hrs.} \times \frac{1}{3}}{1000 \text{ w/kw}} = 0.42\text{kwh}$$

$$\frac{10.5 \text{ sq.ft.} \times 55 \text{ w/sq.ft.} \times 3 \text{ hrs.} \times \frac{1}{3}}{1000 \text{ w/kw}} = 1.16\text{kwh}$$

$$\frac{3 \text{ sq.ft.} \times 27 \text{ w/sq.ft.} \times 3 \text{ hrs.} \times \frac{1}{3}}{1000 \text{ w/kw}} = 0.16\text{kwh}$$

$$= \underline{\underline{1.74\text{kwh}}}$$

#### C. CF

$$20\% (6.25 + 1.74) = \underline{\underline{1.60\text{kwh}}}$$

#### Wattage Required for Process Start-Up:

$$\frac{6.25 + 1.74 + 1.60}{3 \text{ hours}} = \underline{\underline{3.20\text{kw}}}$$

### STEP 2: Wattage Required for Process Operation

$$Q_{ha2} + Q_{ls2} + CF = \text{kw}$$

#### D. Q<sub>ha2</sub>

$$\frac{(235.5 + 75) \text{ lbs.} \times 0.12 \text{ Btu/lb.}^\circ\text{F} \times (150-70)^\circ\text{F}}{3412 \text{ Btu/kwh}} = 0.87\text{kwh}$$

$$\frac{20 \text{ lbs.} \times 0.70 \text{ Btu/lb.}^\circ\text{F} \times (133-70)^\circ\text{F}}{3412 \text{ Btu/kwh}} = 0.26\text{kwh}$$

$$\frac{20 \text{ lbs.} \times 0.71 \text{ Btu/lb.}^\circ\text{F} \times (150-133)^\circ\text{F}}{3412 \text{ Btu/kwh}} = 0.07\text{kwh}$$

$$\frac{\text{Heat of fusion to melt additional paraffin: } 20 \text{ lbs.} \times 63 \text{ Btu/lb.}}{3412 \text{ Btu/kwh}} = 0.37\text{kwh}$$

$$= \underline{\underline{1.57\text{kwh}}}$$

#### E. Q<sub>ls2</sub>

$$\frac{\text{Loss from paraffin surface: } 3 \text{ sq.ft.} \times 70 \text{ w/sq.ft.}}{1000 \text{ w/kw}} = 0.21\text{kwh}$$

$$\frac{\text{Loss from tank vertical surface: } 10.5 \text{ sq.ft.} \times 55 \text{ w/sq.ft.}}{1000 \text{ w/kw}} = 0.58\text{kwh}$$

$$\frac{\text{Loss from tank bottom surface: } 3 \text{ sq.ft.} \times 27 \text{ w/sq.ft.}}{1000 \text{ w/kw}} = 0.08\text{kwh}$$

$$= \underline{\underline{0.87\text{kwh}}}$$

#### G. CF

$$20\% (1.57 + 0.87) = \underline{\underline{0.49\text{kwh}}}$$

#### Wattage Required for Process Operation:

$$1.57 + .87 + .49 = \underline{\underline{2.93\text{kw}}}$$

The results of this particular example were that the start-up and operating wattage requirement were nearly identical. 3.2 kw will be the power installed. As can be seen from 23T, the watt density cannot exceed 16 watts/sq.in. in heating paraffin. As immersion heating is not reasonable, the best heat source would be HD Strip Heaters mounted on the tank bottom. This will provide efficient conductive and convective heat transfer. Accurate temperature control is required as the process is near to the maximum operating temperature of this material, 150°F, which is also found on 23T. A PID control such as an ETR-9090 would be the best selection. The placement of the thermal system components as described will lead to satisfactory process results.

**EXAMPLE 3: SURFACE HEATING**

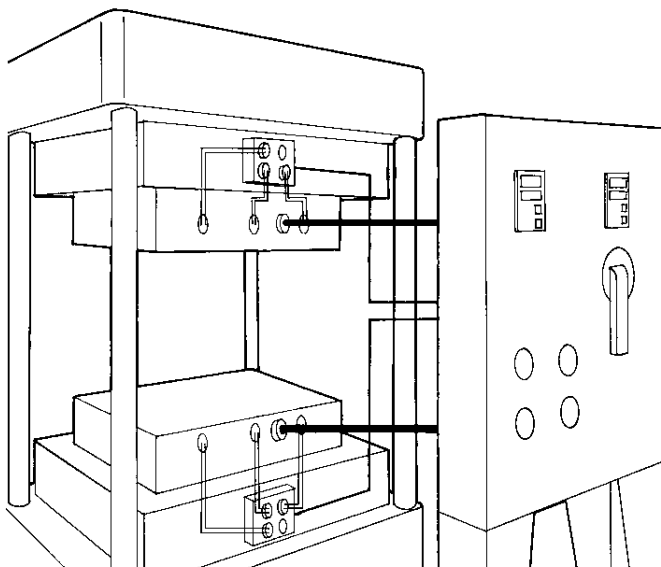

**Description:** A press has two steel platens, each 3ft. X 8ft. X 3" thick. After initial heat-up from 70°F to 350°F in 2 hours, 60 lb. sheets of fiberboard are processed by drying and compressing to 1/4 inch thickness at a rate of 3 per hour. Platens are closed during initial heat-up and open for 2 minutes of the 20 minute working cycle. The horizontal non-working surfaces of the platens are insulated from the press, but the edges are exposed.

**Calculation of wattage required:**

**Considerations:**

Beginning to final temperature: 70–350 °F  
 Time available for process start-up: 2 hours  
 Process cycle period: 20 minutes each sheet  
 3 sheets per hour

Weight and thermal properties of all materials:

Specific heat of steel: 0.12 Btu/lb./°F  
 Specific heat of fiberboard: 0.65 Btu/lb./°F  
 Density of steel: 491 lb./cu.ft.  
 Weight of platens: 2(3X8X.25) cu.ft. X 491lb./cu.ft.  
 = 5892 lb.

Weight of fiberboard: 60 lbs. each sheet  
 180 lbs. per hour

Exposed surface areas and heat losses:

Amount of insulation:  
 No insulation on sides  
 Negligible losses from insulated horizontal surfaces  
 Exposed platen side area: 11 sq.ft.  
 Exposed platen open area: 48 sq.ft.  
 From graph 1T, heat losses from uninsulated metal surfaces:  
 At 350°F—275 watts/sq. ft.

**STEP 1: Wattage Required for Process Start-Up**

$$\begin{aligned} Q_{ha} + Q_{ls} + CF &= \text{kwh} \\ \text{kwh} &= \text{kw} \\ \text{Hours allowed for process start-up} & \end{aligned}$$

**A. Q<sub>ha</sub>**

$$\begin{aligned} \text{To heat platens} \\ \frac{5892 \text{ lb.} \times 0.12 \text{ Btu/lb./}^\circ\text{F} \times (350-70)^\circ\text{F}}{3412 \text{ Btu/kwh}} &= 58.02\text{kwh} \\ + \\ \text{Heat of fusion or vaporization:} &= \text{None} \\ \hline &= \underline{58.02\text{kwh}} \end{aligned}$$

**B. Q<sub>ls</sub>**

$$\begin{aligned} \text{Average loss from uninsulated side areas:} \\ \frac{11 \text{ sq. ft.} \times 275 \text{ w/sq.ft.} \times 2 \text{ hr.}}{1000 \text{ w/kw}} \times \frac{1}{2} &= 3.02\text{kwh} \\ \hline &= \underline{3.02\text{kwh}} \end{aligned}$$

**C. CF**

$$20\%(58.02 + 3.02) = \underline{12.21\text{kwh}}$$

**Wattage Required for Process Start-Up:**

$$\frac{58.02 + 3.02 + 12.21}{2 \text{ hours}} = \underline{\underline{36.62\text{kw}}}$$

**STEP 2: Wattage required for process operation**

$$Q_{ha2} + Q_{ls2} + CF = \text{kw}$$

**D. Q<sub>ha2</sub>**

$$\begin{aligned} \text{To heat fiberboard:} \\ \frac{60 \text{ lb.} \times 0.65 \text{ Btu/lb./}^\circ\text{F} \times (350-70)^\circ\text{F}}{3412 \text{ Btu/kwh}} &= 3.20\text{kwh} \\ + \\ \text{Heat of fusion or vaporization:} &= \text{None} \\ \hline &= \underline{3.20\text{kwh}} \end{aligned}$$

**E. Q<sub>ls2</sub>**

$$\begin{aligned} \text{Loss from uninsulated side areas:} \\ \frac{11 \text{ sq.ft.} \times 275 \text{ w/sq.ft.} \times 0.33 \text{ hr.}}{1000 \text{ w/kw}} &= 1.00\text{kwh} \\ + \\ \text{Loss from open platen:} \\ \frac{48 \text{ sq.ft.} \times 275 \text{ w/sq.ft.} \times 0.33 \text{ hr.}}{1000 \text{ w/kw}} &= 4.36\text{kwh} \\ \hline &= \underline{5.36\text{kwh}} \end{aligned}$$

**F. CF**

$$20\%(3.20 + 5.36) = \underline{1.71\text{kwh}}$$

Wattage required for each 20 minute cycle:

$$3.20 + 5.36 + 1.71 = 10.27\text{kwh}$$

**Wattage Required for Process Operation:**

$$\frac{10.27 \text{ kw/cycle}}{.33 \text{ hr./cycle}} = \underline{\underline{31.12\text{kw}}}$$

As the start-up and operating requirements are close, 36.62kw will be installed.

This system is a large thermal mass with control accuracy requirements at a minimum because of the non-critical temperatures of the process in relation to the product. HD Strip Heaters or tubular heaters in milled slots or cartridge or tubular heaters in drilled holes would be acceptable heat sources for this application. Both the top and bottom platens would be sensed and if greater accuracy was desired, each platen could be zoned.

**EXAMPLE 4: PROCESS AIR HEATING**

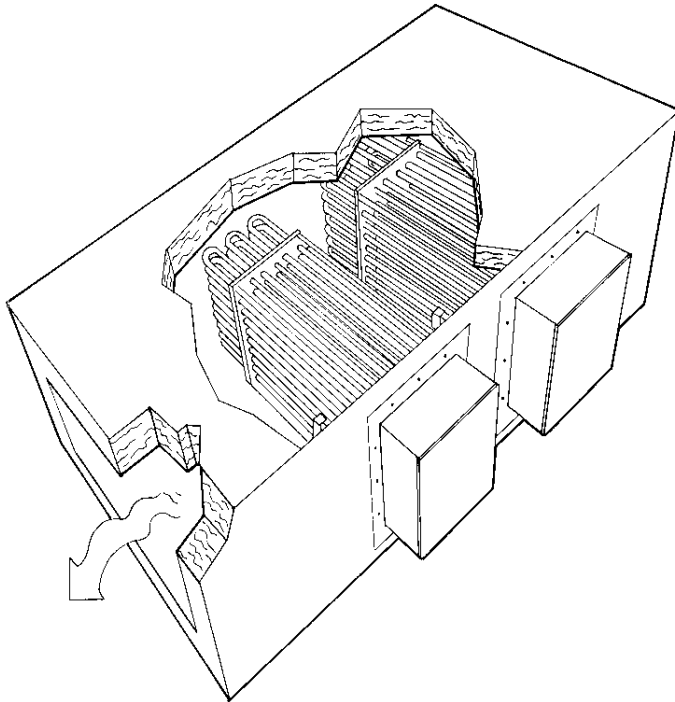

**Description:** A drying process requires 2500 cubic feet of air per minute at 275°F. Incoming air temperature has already been heated to 200°F along the way. The air will need to travel an additional 10 feet from the heater exhaust to the process. Dimensions of the duct are 24" wide x 24" high and is covered with 2" of insulation. There is no recirculation of the air. As this is a continuous process, start-up calculations are not required.

**Calculation of wattage required:**

**Considerations:**

Beginning to final temperature: 200–275°F  
 Duct opening: 2 ft. x 2 ft.

Weight and thermal properties of all materials:

From 10T, average specific heat of air:  
 specific heat at 200°F = 0.242 Btu/lb./°F  
 specific heat at 275°F = 0.243 Btu/lb./°F

$$\text{Average} = \frac{.242 + .243}{2} = .2425 \text{ Btu/lb./}^\circ\text{F}$$

From 10T, density of air at 200°F: 0.060 lb./cu.ft.  
 From 10T, density of air at 275°F: 0.054 lb./cu.ft.

Weight of air processed per hour:  
 2500 cfm x 0.060 lb./cu.ft. x 60 min./hr. = 9000 lbs.

Exposed surface areas and heat losses:  
 Amount of insulation: 2"  
 Surface area of duct: 80 sq.ft.  
 From graph 2T, heat losses from insulated surfaces at 275°F: 5 watts/sq.ft.

**STEP 2: Wattage Required for Process Operation**

$$Q_{ha2} + Q_{ls2} + CF = \text{kwh}$$

**D. Q<sub>ha2</sub>**

$$\frac{9000 \text{ lbs.} \times 0.2425 \text{ Btu/lb./}^\circ\text{F} \times (275-200)^\circ\text{F}}{3412 \text{ Btu/kwh}} = 47.97\text{kwh}$$

$$= \underline{47.97\text{kwh}}$$

**E. Q<sub>ls2</sub>**

$$\begin{aligned} \text{Losses from insulated duct surface:} \\ \frac{80 \text{ sq.ft.} \times 5 \text{ w/sq.ft.} \times 1 \text{ hr.}}{1000 \text{ w/kwh}} &= 0.40\text{kwh} \\ &= \underline{0.40\text{kwh}} \end{aligned}$$

**F. CF**

$$20\%(47.97 + 0.40) = \underline{9.67\text{kwh}}$$

**Wattage Required for Process Operation:**

$$47.97 + 0.40 + 9.67 = \underline{58.04\text{kwh}}$$

To select the appropriate heater as to the type and watt density, it is necessary to determine the outlet velocity. Each OGDEN Process Air Heater has maximum outlet air temperatures based upon the air velocity. Air and other gases' molecules move further apart as heating occurs, causing the density to decrease (become lighter) as the temperature increases. Because the area the gas passes through in a duct heater is constant, the velocity increases. It is important to note that the difference between the inlet velocity and density and the outlet velocity and density could be significant based upon the temperature differential of the two. See 50T. If air velocity versus outlet air temperature is not within catalog guidelines, element overheating and failure will occur.

To determine the Outlet Velocity:

$$\text{Outlet Velocity (fpm}_2) = \text{Inlet Velocity (fpm}_1) \times \frac{\text{Inlet Density}}{\text{Outlet Density}}$$

To determine the Inlet Velocity:

$$\text{Inlet Velocity (fpm}_1) = \frac{\text{cfm}}{\text{Duct Opening (sq. ft.)}}$$

From Example 4:

$$\begin{aligned} \text{Inlet Velocity (fpm}_1) &= \frac{2500}{2 \times 2} \\ &= 625 \text{ fpm} \end{aligned}$$

$$\begin{aligned} \text{Outlet Velocity (fpm}_2) &= 625 \text{ fpm} \times \frac{2500 \text{ cfm} \times 0.060 \text{ lb./cu.ft.}}{2500 \text{ cfm} \times 0.054 \text{ lb./cu.ft.}} \\ &= 625 \text{ fpm} \times \frac{150}{135} \end{aligned}$$

$$\begin{aligned} &= 694.4 \text{ fpm} \\ \text{fps} &= \frac{695 \text{ fpm}}{60 \text{ sec/min}} \\ \text{fps} &= 11.57 \end{aligned}$$

Based upon the requirement of 58.04 kw and that the outlet velocity versus the outlet temperature is well within the limitations of the ODH Process Air Heaters as shown in that catalog section, a proper selection would be the ODH-60. In further checking, a tubular heater at 22 watts per square inch operating in distributed air of 9 fps would be producing less than 1000°F sheath temperature per Chart 15T. As this process is over 11 fps, element temperature will never be a problem as long as this velocity exists. To be certain, a type K thermocouple will be attached to an element to provide input to a limit control. The process sensor should be mounted down-stream from the heater to be certain the temperature is 275°F at the process. An ETR Temperature Control will provide satisfactory process control.

E. QIs2

$$\frac{\text{Loss from insulated vertical and top oven surfaces:}}{1000 \text{ w/kw}} = 0.06\text{kwh}$$
$$\frac{32 \text{ sq.ft.} \times 8 \text{ w/sq.ft.} \times .25 \text{ hrs.}}{1000 \text{ w/kw}} = 0.06\text{kwh}$$

$$\frac{\text{Loss from insulated bottom oven surface:}}{1000 \text{ w/kw}} = 0.01\text{kwh}$$
$$\frac{8 \text{ sq.ft.} \times 4 \text{ w/sq.ft.} \times .25 \text{ hrs.}}{1000 \text{ w/kw}} = 0.01\text{kwh}$$
$$= \underline{0.07\text{kwh}}$$

F. CF

$$\text{Wattage required for each 15 minute cycle:}$$
$$30\% (1.18 + 0.07) = \underline{0.38\text{kwh}}$$
$$1.18 + 0.07 + 0.38 = 1.63\text{kwh}$$

**Wattage Required for Process Operation:**

$$\frac{1.63 \text{ kw/cycle}}{.25 \text{ hr./cycle}} = \underline{\underline{6.52\text{kw}}}$$

As can be seen, a 30% contingency factor was utilized in this process. Additional heat losses will likely occur as the oven doors are frequently opened. As the wattage requirement for the start-up is greater than the operating requirement, 7.75kw will be installed. The extra wattage can be considered an additional safety measure. Either tubular heaters or HD Strip Heaters mounted to the oven wall would be acceptable. A time proportioning ETR Temperature Control with an exposed junction type J thermocouple would provide the proper control.

# DETERMINING WATT DENSITY

## IMMERSION HEATERS:

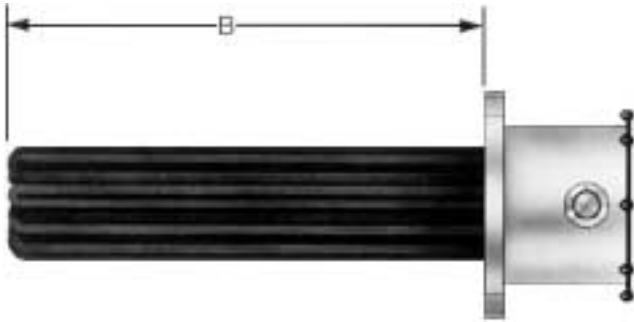

$$B \text{ dim.} = \frac{\text{EHL}}{\# \text{elements} \times 2} + \text{cold area}$$

$$\text{EHL} = (\# \text{ elements} \times 2 \times B) - (\text{cold area} \times \# \text{ elements} \times 2)$$

$$\text{EHL} = \frac{\text{Wattage}}{\text{element dia.} \times \text{w/sq.in.} \times \pi}$$

$$\text{Watt Density (w/sq.in.)} = \frac{\text{Wattage}}{\text{element dia.} \times \text{EHL} \times \pi}$$

To determine the watt density when kw and immersion depth (B dim.) are known:

Assume—25kw

B = 30" (6 cold area)

6" Flanged Immersion Heater—18 elements

Find—Watt density

$$\text{EHL} = (18 \times 2 \times 30) - (6 \times 18 \times 2)$$

$$\text{EHL} = 864"$$

$$\text{Watt density} = \frac{25000}{.475 \times 864 \times \pi}$$

$$\text{Watt density} = 19.4 \text{ w/sq.in.}$$

To determine immersion depth when kw and watt density limitations are known:

Assume—48kw  
22w/sq.in.

8" Flanged Immersion Heater  
24 elements (6" cold area)

Find—B dimension

$$\text{EHL} = \frac{48000}{.475 \times 22 \times \pi}$$

$$\text{EHL} = 1463"$$

$$B = \frac{1463}{(24 \times 2)} + 6$$

$$B = 36\frac{1}{2}"$$

## ESTIMATING SHEATH WATT DENSITY FOR OTHER PRODUCTS

### BAND HEATERS:

$$\text{Watts/sq.in.} = \frac{\text{Wattage}}{(\text{dia} \times \pi \times \text{width}) - \text{width}}$$

See respective catalog section for each band heater for accurate watt density formulas.

### CARTRIDGE AND TUBULAR HEATERS:

$$\text{Watts/sq.in.} = \frac{\text{Wattage}}{\text{dia.} \times \text{heated length} \times \pi}$$

### MICA STRIP HEATERS:

$$\text{Watts/sq.in.} = \frac{\text{Wattage}}{(\text{heated length} \times \text{width}) - \text{width}}$$

### HD STRIP HEATERS:

$$\text{Watts/sq.in.} = \frac{\text{Wattage}}{\text{heated length} \times 3.75}$$

### CHANNEL HEATERS:

$$\text{Watts/sq.in.} = \frac{\text{Wattage}}{\text{heated length} \times 3.625}$$

# PRESSURE/TEMPERATURE RATINGS OF STEEL AND STAINLESS STEEL FLANGES

150 lb. Flange

Material	Carbon steel			STAINLESS STEEL					
	Temp. °F	Norm.	High	Low	Type	Type	Types	Type	Types
					304	316	304L	316L	321
-20 to 100	285	290	235	275	275	230	275	275	
200	260	260	215	235	240	195	235	245	
300	230	230	210	205	215	175	210	225	
400		200		180	195	160	190	200	
500		170			170	145		170	
600		140			140	140		140	
650		125			125	125		125	
700		110			110	110		110	
750		95			95	95		95	
800		80			80	80		80	
850					65	65		65	
900					50			50	
950					35			35	
1000					20			20	

Pressure in Pounds per square inch, gage (psig)

300 lb. Flange

Material	Carbon steel			STAINLESS STEEL					
	Temp. °F	Norm.	High	Low	Type	Type	Types	Type	Types
					304	316	304L	316L	321
-20 to 100	740	750	620	720	720	600	720	720	
200	675	750	560	600	620	505	610	635	
300	655	730	550	530	560	455	545	590	
400	635	705	530	470	515	415	495	555	
500	600	665	500	435	480	380	460	520	
600	550	605	455	415	450	360	435	490	
650	535	590	450	410	445	350	430	480	
700	535	570	450	405	430	345	420	470	
750	505	505	445	400	425	335	415	460	
800	410	410	370	395	415	330	415	455	
850		270		390	405	320	410	445	
900		170		385	395		405	430	
950		105		375	385		385	385	
1000		50		325	365		355	365	
1050				310	360		345	360	
1100				260	325		300	325	
1150				195	275		235	275	
1200				155	205		180	170	
1250				110	180		140	125	
1300				85	140		105	95	
1350				60	105		80	70	
1400				50	75		60	50	
1450				35	60		50	40	
1500				25	40		40	35	

Pressure in Pounds per square inch, gage (psig)

600 lb. Flange

Material	Carbon steel			STAINLESS STEEL					
	Temp. °F	Norm.	High	Low	Type	Type	Types	Type	Types
					304	316	304L	316L	321
-20 to 100	1480	1550	1235	1440	1440	1200	1440	1440	
200	1350	1500	1225	1200	1240	1015	1220	1270	
300	1315	1455	1095	1055	1120	910	1090	1175	
400	1270	1410	1060	940	1030	825	990	1110	
500	1200	1330	995	875	955	765	915	1035	
600	1095	1210	915	830	905	720	875	985	
650	1075	1175	895	815	890	700	855	960	
700	1065	1135	895	805	865	685	840	935	
750	1010	1010	885	795	845	670	830	920	
800	825	825	740	790	830	660	825	910	
850		535		780	810	645	815	890	
900		345		770	790		810	865	
950		205		750	775		775	775	
1000		105		645	725		715	725	
1050				620	720		695	720	
1100				515	645		605	645	
1150				390	550		475	550	
1200				310	410		365	345	
1250				220	365		280	245	
1300				165	275		210	185	
1350				120	205		165	135	
1400				90	150		125	105	
1450				70	115		95	80	
1500				50	85		75	70	

Pressure in Pounds per square inch, gage (psig)

# TANK CAPACITIES

## VERTICAL CYLINDER

Dia (in)	Dia (ft)	Surface Area (sq ft)	Volume per 1' depth (Gal)	Dia (in)	Dia (ft)	Area (sq ft)	Volume per 1' depth (Gal)	Dia (in)	Dia (ft)	Area (sq ft)	Volume per 1' depth (Gal)	Dia (in)	Dia (ft)	Area (sq ft)	Volume per 1' depth (Gal)
2	0.167	9.222	0.163	45	3.750	11.04	82.62	120	10.0	78.54	587.5	396	33	855.3	6398
3	0.250	0.049	0.367	46	3.833	11.54	86.33	126	10.5	86.59	647.7	408	34	907.9	6792
4	0.333	0.087	0.653	47	3.917	12.05	90.13	132	11.0	95.03	710.9	420	35	962.1	7197
5	0.417	0.136	1.020	48	4.000	12.57	94.00	138	11.5	103.9	777.0	432	36	1018	7614
6	0.500	0.196	1.469	49	4.083	13.10	97.96	144	12.0	113.1	846.0	444	37	1075	8043
7	0.583	0.267	1.999	50	4.167	13.64	102.0	150	12.5	122.7	918.0	456	38	1134	8484
8	0.667	0.349	2.611	51	4.250	14.19	106.1	156	13.0	132.7	992.9	468	39	1195	8936
9	0.750	0.442	3.305	52	4.333	14.75	110.3	162	13.5	143.1	1071	480	40	1257	9400
10	0.833	0.545	4.080	53	4.417	15.32	114.6	168	14.0	153.9	1152	492	41	1320	9976
11	0.917	0.660	4.937	54	4.500	15.90	119.0	174	14.5	165.1	1235	504	42	1385	10364
12	1.000	0.785	5.875	55	4.583	16.50	123.4	180	15.0	176.7	1322	516	43	1452	10863
13	1.083	0.922	6.895	56	4.667	17.10	127.9	186	15.5	188.7	1412	528	44	1521	11374
14	1.167	1.069	7.997	57	4.750	17.72	132.6	192	16.0	201.1	1504	540	45	1590	11897
15	1.250	1.227	9.180	58	4.833	18.35	137.3	198	16.5	213.8	1600	552	46	1662	12432
16	1.333	1.396	10.44	59	4.917	18.99	142.0	204	17.0	227.0	1698	564	47	1735	12978
17	1.417	1.576	11.79	60	5.000	19.63	146.9	210	17.5	240.5	1799	576	48	1810	13536
18	1.500	1.767	13.22	61	5.083	20.29	151.8	216	18.0	254.5	1904	588	49	1886	14106
19	1.583	1.969	14.73	62	5.167	20.97	156.8	222	18.5	268.8	2011	600	50	1963	14688
20	1.667	2.182	16.32	63	5.250	21.65	161.9	228	19.0	283.5	2121	624	52	2124	15887
21	1.750	2.405	17.99	64	5.333	22.34	167.1	234	19.5	298.6	2234	648	54	2290	17132
22	1.833	2.640	19.75	65	5.417	23.04	172.4	240	20.0	314.2	2350	672	56	2463	18425
23	1.917	2.885	21.58	66	5.500	23.76	177.7	246	20.5	330.1	2469	696	58	2642	19764
24	2.000	3.142	23.50	67	5.583	24.48	183.2	252	21.0	346.4	2591	720	60	2827	21151
25	2.083	3.409	25.50	68	5.667	25.22	188.7	258	21.5	363.1	2716	744	62	3019	22584
26	2.167	3.687	27.58	69	5.750	25.97	194.2	264	22.0	380.1	2844	768	64	3217	24065
27	2.250	3.976	29.74	70	5.833	26.73	199.9	270	22.5	397.6	2974	792	66	3421	25592
28	2.333	4.276	31.99	71	5.917	27.49	205.7	276	23.0	415.5	3108	816	68	3632	27167
29	2.417	4.587	34.31	72	6.000	28.27	211.5	282	23.5	433.7	3245	840	70	3848	28788
30	2.500	4.909	36.72	75	6.25	30.68	229.5	288	24.0	452.4	3384	864	72	4072	30457
31	2.583	5.241	39.21	78	6.50	33.18	248.2	294	24.5	471.4	3527	888	74	4301	32173
32	2.667	5.585	41.78	81	6.75	35.78	267.7	300	25.0	490.9	3672	912	76	4536	33935
33	2.750	5.940	44.43	84	7.00	38.48	287.9	306	25.5	510.7	3820	936	78	4778	35745
34	2.833	6.305	47.16	87	7.25	41.28	308.8	312	26.0	530.9	3972	960	80	5027	37601
35	2.917	6.681	49.98	90	7.50	44.18	330.5	318	26.5	551.5	4126	984	82	5281	39505
36	3.000	7.069	52.88	93	7.75	47.17	352.9	324	27.0	572.6	4283	1008	84	5542	41455
37	3.083	7.467	55.86	96	8.00	50.27	376.0	330	27.5	594.0	4443	1032	86	5809	43453
38	3.167	7.876	58.92	99	8.25	53.46	399.9	447	38.0	615.8	4606	1056	88	6082	45497
39	3.250	8.296	62.06	102	8.50	56.75	424.5	442	38.5	637.9	4772	1080	90	6362	47589
40	3.333	8.727	65.28	105	8.75	60.13	449.8	448	39.0	660.5	4941	1104	92	6648	49728
41	3.417	9.168	68.58	108	9.00	63.62	475.9	454	39.5	683.5	5113	1128	94	6940	51913
42	3.500	9.621	71.97	111	9.25	67.20	502.7	460	40.0	706.9	5288	1152	96	7238	54146
43	3.583	10.08	75.44	114	9.50	70.88	530.2	466	40.5	730.8	5466	1176	98	7543	56425
44	3.667	10.56	78.99	117	9.75	74.66	558.5	472	41.0	755.2	5646	1200	100	7854	58752

## HORIZONTAL CYLINDER

Contents in gallons per foot of length of tank with flat ends when filled to various depths.

Tank Dia (in)	Depth of Liquid, h (in)																					
	Full Tank	3	6	9	12	15	18	21	24	27	30	33	36	39	42	45	48	51	54	57	60	
6	1.47	0.73	1.47																			
12	5.88	1.15	2.94	4.73	5.88																	
18	13.22	1.45	3.86	6.61	9.36	11.77	13.22															
24	23.50	1.70	4.59	8.05	11.75	15.45	18.91	21.81	23.50	27	30											
30	36.72	1.91	5.23	9.27	13.72	18.36	23.00	27.45	31.49	34.81	36.72											
36	52.88	2.10	5.79	10.34	15.43	20.85	26.44	32.02	37.45	42.54	47.08	50.77	52.88									
42	71.97	2.28	6.31	11.31	16.97	23.07	29.46	35.99	42.51	48.90	55.00	60.66	65.66	69.69	71.97	45	48					
48	94.00	2.45	6.78	12.20	18.38	25.10	32.20	39.54	47.00	54.46	61.81	68.91	75.63	81.80	87.22	91.56	94.00	51	54			
54	118.97	2.60	7.23	13.03	19.69	26.97	34.72	42.79	51.09	59.49	67.88	76.18	84.26	92.00	101.07	109.82	118.16	125.97	133.06	139.24		
60	146.88	2.75	7.64	13.82	20.91	28.72	37.06	45.81	54.86	64.10	73.44	82.77	92.02	101.07	110.82	120.03	128.91	137.58	146.00	154.24	162.24	170.00
66	117.72	2.88	8.04	14.56	22.07	30.36	39.26	48.64	58.39	68.40	78.59	88.86	99.13	109.32	119.33	129.08	138.46	147.36	155.65	163.17	169.88	
72	211.51	3.02	8.42	15.26	23.17	31.92	41.35	51.32	61.72	72.45	83.42	94.55	105.75	116.96	128.09	139.06	149.79	160.19	170.16	179.58	188.34	
78	248.23	3.14	8.78	15.93	24.22	33.41	43.33	53.86	64.87	76.27	87.97	99.90	111.97	124.11	136.26	148.33	160.25	171.96	183.36	194.37	204.89	
84	287.88	3.26	9.13	16.58	25.23	34.84	45.23	56.28	67.87	79.91	92.30	104.97	117.85	130.86	143.94	157.02	170.03	182.91	195.58	207.98	220.01	
90	330.48	3.38	9.46	17.20	26.19	36.20	47.05	58.61	70.75	83.39	96.43	109.81	123.44	137.27	151.22	165.24	179.26	193.21	207.04	220.67	234.05	
96	376.01	3.49	9.78	17.80	27.13	37.52	48.81	60.84	73.51	86.72	100.39	114.44	128.79	143.39	158.16	173.05	188.01	202.96	217.85	232.62	247.22	
102	424.48	3.60	10.10	18.38	28.03	38.80	50.50	62.99	76.17	89.94	104.20	118.88	133.92	149.25	164.80	180.52	196.35	212.24	228.13	243.96	259.68	
108	475.89	3.71	10.40	18.94	28.90	40.02	52.13	65.08	78.74	93.04	107.87	123.17	138.86	154.88	171.18	187.69	204.35	221.12	237.95	254.77	271.54	
114	530.24	3.81	10.70	19.49	29.75	41.23	53.72	67.10	81.23	96.04	111.42	127.31	143.63	160.32	177.32	194.58	212.04	229.65	247.36	265.12	282.88	
120	587.52	3.91	10.98	20.02	30.58	42.39	55.26	69.06	83.65	98.95	114.86	131.31	148.24	165.57	183.26	201.24	219.46	237.87	256.42	275.07	293.76	

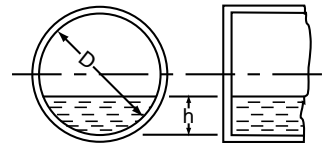

# SATURATED STEAM

## Thermodynamic Properties – Saturated Steam (Values to Nearest Even Digits)

PSIG	°F	BTU/lb.			Spec. Vol. Ft <sup>3</sup> /lb Sat. Vapor
		Heat of Liquid*	Latent Heat of Evaporation	Total Heat of Steam	
0	212	180	970	1150	27
1	216	183	968	1151	25
2	219	187	965	1152	24
3	222	190	964	1154	22.5
4	224	193	962	1155	21.0
5	227	195	961	1156	20.0
6	230	298	959	1157	19.5
7	232	201	957	1158	18.5
8	235	203	956	1159	18.0
9	237	206	954	1160	17.0
10	240	208	952	1160	16.5
15	250	218	945	1163	14.0
20	259	227	940	1167	12.0
25	267	236	934	1170	10.5
30	274	243	929	1172	9.5
35	281	250	924	1174	8.5
40	287	256	920	1176	8.0
45	292	262	915	1177	7.0
50	298	267	912	1179	6.7
55	303	272	908	1180	6.2
60	307	277	905	1182	5.8

PSIG	°F	BTU/lb.			Spec. Vol. Ft <sup>3</sup> /lb Sat. Vapor
		Heat of Liquid*	Latent Heat of Evaporation	Total Heat of Steam	
65	312	282	901	1183	5.5
70	316	286	898	1184	5.2
75	320	290	895	1185	4.9
80	324	294	892	1186	4.7
85	328	298	889	1187	4.4
90	331	302	886	1188	4.2
95	335	306	883	1189	4.0
100	338	309	881	1190	3.9
110	344	316	876	1192	3.6
120	350	322	871	1193	3.3
125	353	325	868	1193	3.2
130	356	328	866	1194	3.1
140	361	334	861	1195	2.9
150	366	339	857	1196	2.7
160	371	344	853	1197	2.6
170	375	348	849	1197	2.5
180	380	353	845	1198	2.3
190	384	358	841	1199	2.2
200	388	362	837	1199	2.1
220	395	370	830	1200	2.0
240	403	378	823	1201	1.8
250	406	381	820	1201	1.75

\* Heat content is the number of BTU/lb needed to reach the condition indicated starting with water at 32°F.

Saturated steam is pure steam in direct contact with the liquid water from which it was generated and at a temperature of water at the existing pressure. For example, saturated steam at 50 PSIG has a temperature of 298°F.

Pressure is commonly expressed either (a) PSIA – pounds per square inch absolute or, (b) PSIG – pounds per square inch gauge above

standard atmospheric pressure of 14.7 PSIA, thus PSIG is equal to PSIA minus 14.7 psi.

Latent heat, expressed in BTU per pound, is the amount of heat needed (absorbed) to convert a pound of boiling water to a pound of steam. The same amount of heat is liberated when a pound of steam condenses back to a pound of water. Latent heat varies with temperature (see table above).

# SHEATH MATERIAL COMPOSITION

Sheath Material	Chemical Composition														Notes			
	Al	C	Co	Cr	Cu	Fe	Mn	Mo	Ni	P	S	Si	Ta	Ti		V	W	
Steel—1010 Carbon		.08/.13				Bal	.3/.6			.04	.05							
<b>Stainless Steels</b>																		
304		.08		18/20		Bal	2		8/10.5	.045	.03	1						
316		.08		16/18		Bal	2	2/3	10/14	.045	.03	1						
316L		.03		16/18		Bal	2	2/3	10/14	.045	.03	1						
321		.08		17/19		Bal	2		9/12	.045	.03	1						
347		.08		17/19		Bal	2		9/13	.045	.03	1						
Carpenter 20Cb-3		.06		19/21	3/4	Bal	2	2/3	32/38	.05	.035	1						
																		Ti = 5 × C Cb + Ta = 10 × C  Cb + Ta = 1% max.
<b>Nickel Alloys</b>																		
Incoloy 800	.38	.05		21	.38	Bal	.75		32.5		.008	.5		.38				
Incoloy 840		.08		18/22	.075	Bal	1		18/22		.015	1.0						
Monel 400		.15			Bal	1.25	1		66.5		.012	.25	.25					
Inconel 600		.08		15.5	.25	8	.5		76		.008	.25	.25					
																		Nickel + Cobalt = 76% min.

# TERMINAL ENCLOSURE DESCRIPTIONS

## M1—GENERAL PURPOSE (NEMA 1)

Nonventilated enclosure to prevent accidental contact with enclosed apparatus, suitable for use indoors where not subjected to any unusual operating conditions, to provide protection against dirt, light and indirect splashing, but not dust tight.

## M5—MOISTURE RESISTANT

## M6—EXPLOSION RESISTANT

## M7—COMBINATION MOISTURE TIGHT, EXPLOSION RESISTANT

### Specifying an Explosion Resistant Electrical Enclosure

#### CLASSIFICATION OF HAZARDOUS ATMOSPHERES: (Based on National Electrical Code and UL)

Class	Division	Group	Typical atmosphere/ignition temps.	Devices Covered	Temperature Measured	Limiting Value
I Gases, vapors	1 Normally hazardous	A	acetylene (325C, 581F)	All electrical devices and wiring	Maximum external temperature in 40C ambient	See Sect. 501-2 of NEC
		B	butadiene (470C, 786F) ethylene oxide (429C, 804F) hydrogen (409C, 752F) manufactured gases containing more than 30% hydrogen (by volume) propylene oxide (445C, 840F)			
		C	acetaldehyde (175C, 347F) cyclopropane (500C, 932F) diethyl ether (150C, 320F) ethylene (490C, 914F) asymmetrical dimethyl hydrazine (UDMH 1, 1-dimethyl hydrazine) (249C, 480F)			
		D	acetone (465C, 869F) acrylonitrile (483C, 898F) ammonia (551C, 1024F) benzene (560C, 1040F) butane (405C, 761F) 1-butanol (butyl alcohol) (355C, 689F) 2-butanol (secondary butyl alcohol) (405C, 761F) n-butyl acetate (425C, 797F) isobutyl acetate (421C, 790F) ethene (315C, 599F) ethanol (ethyl alcohol) (356C, 689F) ethyl acetate (472C, 880F) ethylene dichloride (413C, 775F) gasolins (50-80 octane: 260C, 536F) (100 octane: 456C, 853F) heptanes (280C, 536F) hexanes (225C, 437F) isoprene (220C, 428F) methane (natural gas) 482 to 632C, 900 to 1170F) methanol (methyl alcohol) (385C, 725F) 3-methyl-1-butanol (isomer) alcohol (350C, 662F) methyl ethyl ketone (516C, 962F) methyl isobutyl ketone (490C, 890F) 2-methyl-1-propanol (isobutyl alcohol) (427C, 800F) 2-methyl-2-propanol (tertiary butyl alcohol) (460C, 896F) petroleum naphtha (288C, 550F) octanes (220C, 428F) pentanes (260C, 508F) 1-pentanol (amyl alcohol) (300C, 572F) propane (450C, 842F) 1-propanol (propyl alcohol) (440C, 824F) 2-propanol (isopropyl alcohol) (398C, 750F) polykine (460C, 860F) styrene (490C, 914F) toluene (480C, 896F) vinyl acetate (427C, 800F) vinyl chloride (472C, 880F) xylenes (530C, 986F)	<ol style="list-style-type: none"> <li>1) Group D equipment shall be permitted for this atmosphere if such equipment is isolated in accordance with Section 501-5(a) by sealing all conduit 1/2-inch size or larger.</li> <li>2) Group C equipment shall be permitted for this atmosphere if such equipment is isolated in accordance with Section 501-5(a) by sealing all conduit 1/2-inch size or larger.</li> <li>3) For Classification of areas involving ammonia atmosphere, see Safety Code for Mechanical Refrigeration (ANSI B9.1-1971) and Safety Requirements for the Storage and Handling of Anhydrous Ammonia (ANSI K61.1-1972).</li> <li>4) A saturated hydrocarbon mixture boiling in the range 20-135°C (68-275°F). Also known by the synonyms benzene, ligroin, petroleum ether or naphtha.</li> </ol> <p>* 1For a complete list noting properties of flammable liquids, gases and solids refer to the latest edition of NFPA No. 325M.</p>		

(Continued) Specifying an Explosion Resistant Electrical Enclosure

Class	Division	Group	Typical atmosphere/ignition temps.	Devices Covered	Temperature Measured	Limiting Value
I Gases Vapors	2 Not normally hazardous	A B C D	Same as Division 1 Same as Division 1 Same as Division 1 Same as Division 1  (Not normally hazardous means that the gases aren't normally present.)	Lamps, resistors, coil etc., other than arcing devices (see Div. 1)	Max. internal or external temp. not to exceed the ignition temperature in degrees Celsius (°C) of the gas or vapor involved	See Sect. 500-2 of NEC
II Combustible dusts	1 Normally hazardous	E	Metal dust, including aluminum, magnesium, and their commercial alloys, and other metals of similarly hazardous characteristics	Devices not subject to overload (switches, meters)	Max. external temp. in 40C ambient with a dust blanket	No overload: E-200C (392F) F-200C (392F) G-185C (329F)
		F	Carbon black, coal, coke dust with more than 8% volatile material.	Devices subject to overload (motors, transformers)		
		G	Flour, starch, grain dusts.			
	2 Not normally hazardous	G	Same as Division 1	Lighting fixtures	Max. external temp. under conditions of use	Group: G-185C (329F)
III Easily ignitable fibers and flyings	1, 2			Lighting fixtures	Max. external temp. under conditions of use	185C (329F)

**M6 and M7 Terminal Enclosures for Use in Hazardous Locations**

CSA LR55274-24

NRTL/C - Certified to U.S. Standards

Class I, Groups B, C, and D

Class II, Groups E, F, and G

Class III

**Special requirements for electric heaters and terminal enclosures in hazardous locations:**

**WIRING**—The proper use of Type M6 and M7 terminal enclosures on electric heaters located in hazardous areas requires that all electrical wiring comply with National Electrical Code (NEC) requirements for hazardous locations

**MAXIMUM TEMPERATURES**— Safe operation in a hazardous location requires the maximum operating temperatures of all exposed surfaces of the heater including temperatures on the outside of the vessel, piping, flanges, pipe plugs, enclosures and other heat conduction parts be limited. The maximum surface temperature permitted in any hazardous location is determined by the flammable liquids, vapors or gases present. The end user or purchaser of the electric heating

equipment is responsible for determining the proper classification of an area and for providing Ogden with hazardous area specifications and requirements for proper equipment design. (NEC Articles 500 and 501 provide guidelines for evaluating and classifying hazardous locations.)

**SAFETY DEVICES**—Approved pressure and/or temperature limiting controls must be used on electric heaters and heating elements to ensure safe operation in the event of system malfunctions.

**Note 1:** Class I Group B locations include Hydrogen gas. These areas require additional conduit seals and thread engagement. Contact Ogden for heaters and terminal enclosures suitable for Class I Group B hazardous locations.

**Maximum Rating for Approval:**

Pipe Plug Immersion Heaters — 225kw 600V

Flanged Immersion Heaters — 225kw 600V

Circulation Heaters — 70kw 600V

Round elements only. Contact Ogden for Mighty-Blades.

# STANDARD PIPE DATA

NOMINAL PIPE SIZE	INSIDE DIAMETER (INCHES)	OUTSIDE DIAMETER (INCHES)	WEIGHT PIPE (LBS/FT)	LENGTH IN FEET CONTAINING ONE CUBIC FOOT	GALLONS IN ONE LINEAR FOOT	WEIGHT WATER (LBS/FT OF PIPE)
¼	.269	.405	.244	2526.000	.0030	.025
¼	.364	.540	.424	1383.800	.0054	.045
⅜	.493	.675	.567	754.360	.0099	.083
½	.622	.840	.850	473.910	.0158	.132
¾	.824	1.050	1.130	270.030	.0277	.231
1	1.049	1.315	1.678	166.620	.0449	.374
1¼	1.380	1.660	2.272	96.275	.0777	.648
1½	1.610	1.900	2.717	70.733	.1058	.882
2	2.067	2.375	3.652	49.913	.1743	1.453
2½	2.469	2.875	5.793	30.077	.2487	2.073
3	3.068	3.500	7.575	19.479	.3840	3.200
3½	3.548	4.000	9.109	14.565	.5136	4.280
4	4.026	4.500	10.790	11.312	.6613	5.510
5	5.047	5.563	14.617	7.198	1.0393	8.660
6	6.065	6.625	18.974	4.984	1.5008	12.510
8	7.981	8.625	28.551	2.878	2.5988	21.680
10	10.020	10.750	40.483	1.826	4.0963	34.100
12	12.000	12.750	49.560	1.274	5.9036	49.000
14	13.250	14.000	54.570	1.046	7.1928	59.700
16	15.250	16.000	62.580	.789	9.5301	79.100
18	17.250	18.000	70.590	.617	12.1928	101.200

# ELECTRICAL DATA

## TYPICAL HEATER CONNECTIONS

### Parallel

Cartridge Heaters are usually wired in a simple parallel connection. Heaters are rated at applied voltage.

### Series (single phase)

Cartridge heaters may be wired in series.

- To reduce wattage in a system, two heaters rated at 240V wired in series will reduce the total wattage to 1/4 of its rated value when 240V is applied. Three similar heaters wired in series will reduce wattage to 1/9 of its rated value.
- For use at higher voltage—two 120V heaters wired in series for use on 240V, or two 240V heaters wired in series for 480V.

### 3 Phase Delta

The most commonly used method of making 3 Phase connections. The heaters are arranged in multiples of 3 for a balanced system.

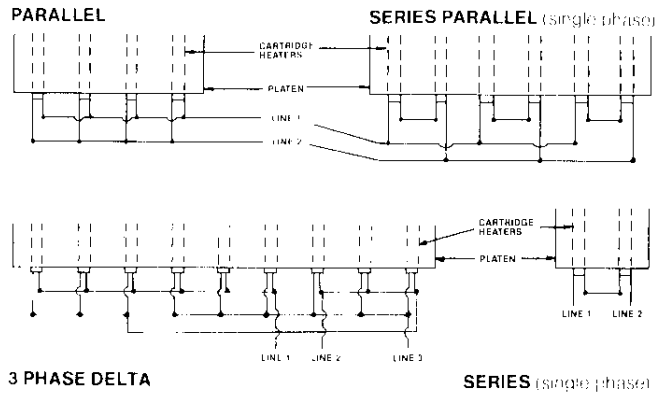

## TYPICAL WIRING DIAGRAMS

### Single Phase

#### AC OR DC HTR CIRCUIT

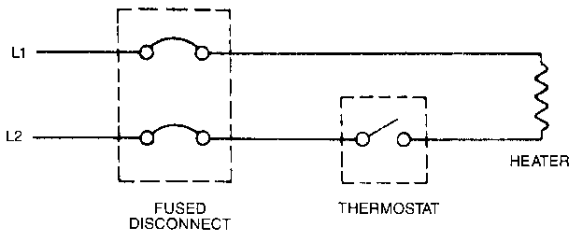

#### CIRCUIT WITH THERMOSTAT CONNECTED FOR HALF CURRENT LOAD ACROSS EACH CONTACT

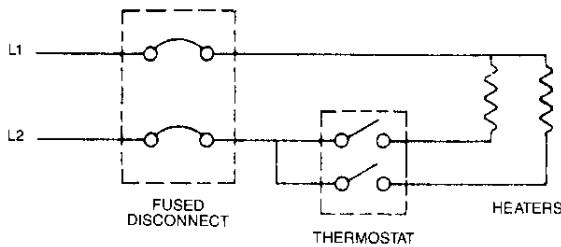

#### TYPICAL CONNECTIONS WHEN LINE CURRENT EXCEEDS THERMOSTAT RATING

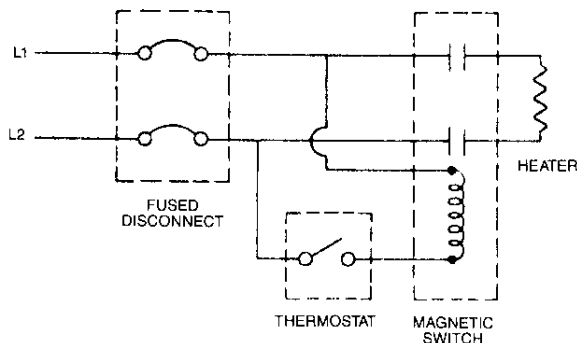

### 3 Phase

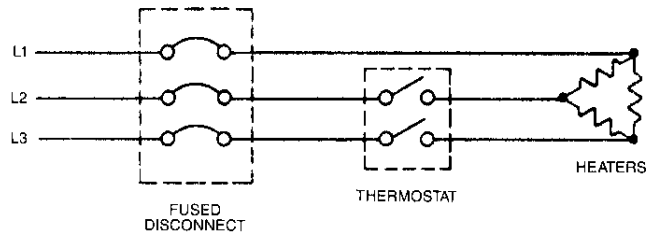

#### TYPICAL CONNECTION WHEN LINE CURRENT EXCEEDS THERMOSTAT RATING

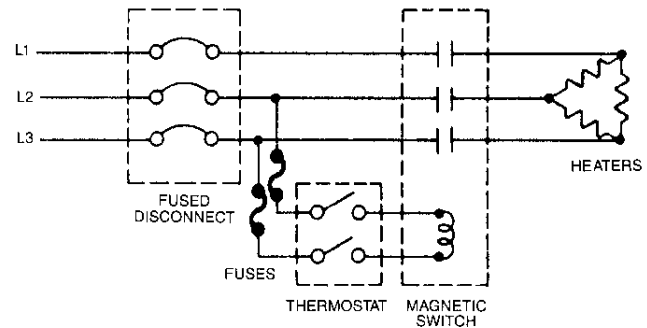

#### TYPICAL CONNECTION WITH ETR TEMPERATURE CONTROL

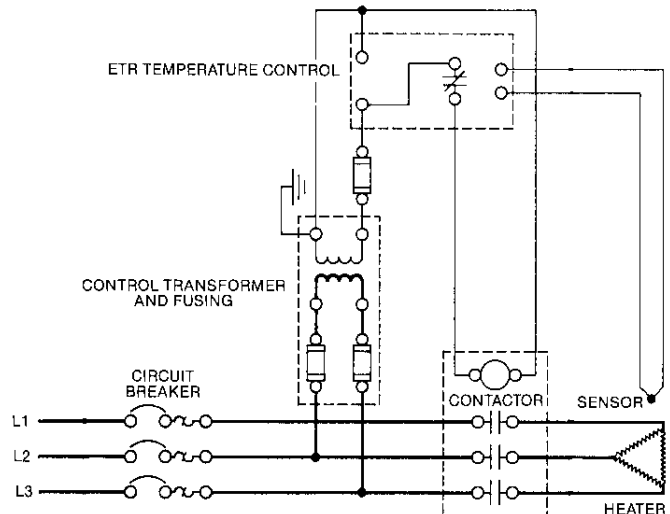

### Wattage Change with Voltage Change

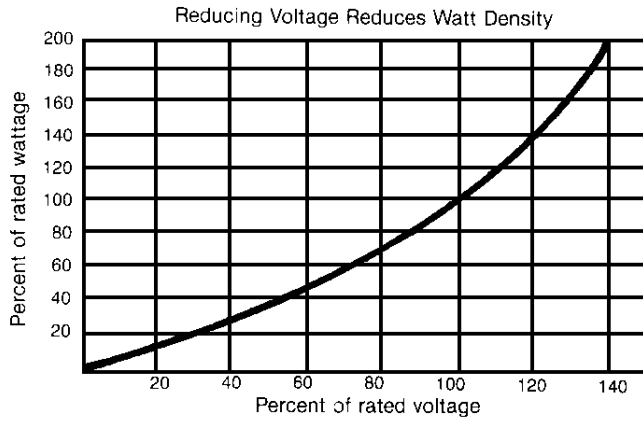

PERCENT RATED WATTS ON REDUCED VOLTAGE	
230-volt heater on 208 volts	—82%
240-volt heater on 208 volts	—75%
480-volt heater on 277 volts	—33%
480-volt heater on 440 volts	—84%
480-volt heater on 318 volts	—44%
550-volt heater on 480 volts	—76%

$$W_2 = W_1 \times \left(\frac{e_2}{e_1}\right)^2$$

Where:

$w_2$  = New wattage output

$w_1$  = Rated wattage

$e_2$  = Applied voltage

$e_1$  = Rated voltage

### Three Phase Circuits

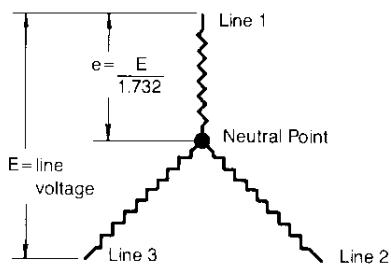

**WYE OR STAR**

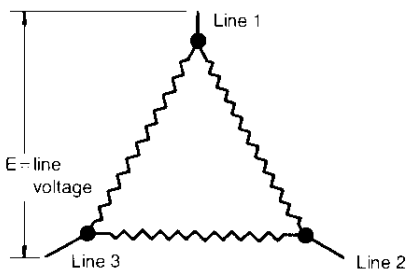

**DELTA**

If elements are designed for 3-phase Delta connection, wattage output may be reduced to  $\frac{1}{3}$  by reconnecting to 3-phase WYE

For current in 3-phase circuits  $I = \frac{W}{E \times 1.732}$

For resistance in 3 phase circuit (across any two terminals)

$$R = \frac{E^2}{\frac{1}{2}W}$$

### ohms Law

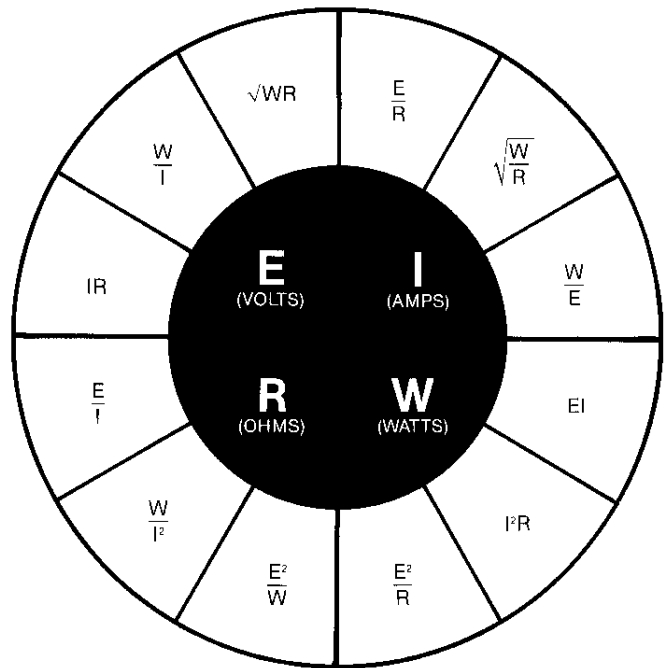

### Amperage Conversion Table

Watts	Volts, Single Phase			Volts 3 Phase Balanced Load		Watts
	120	240	480	240	480	
100	.83	.42	.21	.24	.13	100
150	1.25	.63	.31	.36	.18	150
200	1.67	.83	.42	.49	.25	200
250	2.08	1.04	.52	.61	.30	250
300	2.50	1.25	.63	.73	.37	300
350	2.92	1.46	.73	.85	.43	350
400	3.33	1.67	.84	.97	.49	400
450	3.75	1.88	.93	1.10	.55	450
500	4.17	2.08	1.04	1.20	.60	500
600	5.00	2.50	1.25	1.45	.73	600
700	5.83	2.92	1.46	1.70	.85	700
800	6.67	3.33	1.67	1.93	.97	800
900	7.50	3.75	1.87	2.17	1.09	900
1000	8.33	4.17	2.10	2.41	1.21	1000
1100	9.17	4.58	2.30	2.65	1.33	1100
1200	10.0	5.00	2.51	2.90	1.45	1200
1250	10.4	5.21	2.61	3.10	1.55	1250
1300	10.8	5.42	2.71	3.13	1.57	1300
1400	11.7	5.83	2.91	3.38	1.69	1400
1500	12.5	6.25	3.12	3.62	1.82	1500
1600	13.3	6.67	3.34	3.86	1.93	1600
1700	14.2	7.08	3.54	4.10	2.05	1700
1800	15.0	7.50	3.75	4.34	2.17	1800
1900	15.8	7.92	3.96	4.58	2.29	1900
2000	16.7	8.33	4.17	4.82	2.41	2000
2200	18.3	9.17	4.59	5.30	2.65	2200
2500	20.8	10.4	5.21	6.10	3.05	2500
2750	23.0	11.5	5.73	6.63	3.32	2750
3000	25.0	12.5	6.25	7.23	3.62	3000
3500	29.2	14.6	7.30	8.45	4.23	3500
4000	33.3	16.7	8.33	9.64	4.82	4000
4500	37.5	18.8	9.38	10.84	5.42	4500
5000	41.7	20.8	10.42	12.1	6.1	5000
6000	50.0	25.0	12.50	14.50	7.25	6000
7000	58.3	29.2	14.59	16.9	8.5	7000
8000	66.7	33.3	16.67	19.3	9.65	8000
9000	75.0	37.5	18.75	21.7	10.85	9000
10000	83.3	41.7	20.85	24.1	12.1	10000

# CONVERSION DATA

## Fraction to Decimal to Metric Conversion

FRACTION	DECIMAL	MILLIMETER	FRACTION	DECIMAL	MILLIMETER	FRACTION	DECIMAL	MILLIMETER
$\frac{1}{64}$	0.015625	- 0.397	$\frac{3}{8}$	.359375	- 9.128	$\frac{11}{16}$	.6875	- 17.463
$\frac{1}{32}$	.03125	- 0.794	$\frac{25}{64}$	.3750	- 9.525	$\frac{45}{64}$	.703125	- 17.859
$\frac{3}{64}$	.046875	- 1.191	$\frac{13}{32}$	.40625	- 10.319	$\frac{23}{32}$	.71875	- 18.256
$\frac{1}{16}$	.0625	- 1.588	$\frac{27}{32}$	.421875	- 10.716	$\frac{47}{64}$	.734375	- 18.653
$\frac{5}{64}$	.078125	- 1.984	$\frac{7}{16}$	.4375	- 11.113	$\frac{3}{4}$	.7500	- 19.050
$\frac{3}{32}$	.09375	- 2.381	$\frac{29}{64}$	.453125	- 11.509	$\frac{49}{64}$	.765625	- 19.447
$\frac{1}{8}$	.109375	- 2.778	$\frac{15}{32}$	.46875	- 11.906	$\frac{25}{32}$	.78125	- 19.844
$\frac{9}{64}$	.140625	- 3.572	$\frac{31}{32}$	.484375	- 12.303	$\frac{51}{64}$	.796875	- 20.241
$\frac{5}{32}$	.15625	- 3.969	$\frac{1}{2}$	.5000	- 12.700	$\frac{13}{16}$	.8125	- 20.638
$\frac{11}{32}$	.171875	- 4.366	$\frac{33}{64}$	0.515625	- 13.097	$\frac{53}{64}$	.828125	- 21.034
$\frac{3}{16}$	.1875	- 4.763	$\frac{17}{32}$	.53125	- 13.494	$\frac{27}{32}$	.84375	- 21.431
$\frac{13}{64}$	.203125	- 5.159	$\frac{35}{64}$	.546875	- 13.891	$\frac{55}{64}$	.859375	- 21.828
$\frac{7}{32}$	.21875	- 5.556	$\frac{9}{16}$	.5625	- 14.288	$\frac{7}{8}$	.8750	- 22.225
$\frac{15}{64}$	.234375	- 5.953	$\frac{37}{64}$	.578125	- 14.684	$\frac{57}{64}$	.890625	- 22.622
$\frac{1}{4}$	.2500	- 6.350	$\frac{19}{32}$	.59375	- 15.081	$\frac{29}{32}$	.90625	- 23.019
$\frac{17}{64}$	.265625	- 6.747	$\frac{39}{64}$	.609375	- 15.478	$\frac{59}{64}$	.921875	- 23.416
$\frac{9}{32}$	.28125	- 7.144	$\frac{5}{8}$	.6250	- 15.875	$\frac{15}{16}$	.9375	- 23.813
$\frac{19}{32}$	.296875	- 7.541	$\frac{41}{64}$	.640625	- 16.272	$\frac{61}{64}$	.953125	- 24.209
$\frac{5}{16}$	.3125	- 7.938	$\frac{21}{32}$	.65625	- 16.669	$\frac{31}{32}$	.96875	- 24.606
$\frac{21}{64}$	.328125	- 8.334	$\frac{43}{64}$	.671875	- 17.066	$\frac{63}{64}$	.984375	- 25.003
$\frac{11}{32}$	.34375	- 8.731				$\frac{1}{1}$	1.000	- 25.400
				1 mm = .03937"			.001" = .0254 mm	

## Millimeter to Inch Conversion

MM	INCHES	MM	INCHES	MM	INCHES	MM	INCHES	MM	INCHES
.1-	.0039	14-	.5512	36-	1.4173	58-	2.2835	80-	3.1496
.2-	.0079	15-	.5906	37-	1.4567	59-	2.3228	81-	3.1890
.3-	.0018	16-	.6299	38-	1.4961	60-	2.3622	82-	3.2283
.4-	.0157	17-	.6693	39-	1.5354	61-	2.4016	83-	3.2677
.5-	.0197	18-	.7087	40-	1.5748	62-	2.4409	84-	3.3071
.6-	.0236	19-	.7480	41-	1.6142	63-	2.4803	85-	3.3465
.7-	.0276	20-	.7874	42-	1.6535	64-	2.5197	86-	3.3858
.8-	.0315	21-	.8268	43-	1.6929	65-	2.5591	87-	3.4252
.9-	.0354	22-	.8661	44-	1.7323	66-	2.5984	88-	3.4646
1-	.0394	23-	.9055	45-	1.7717	67-	2.6378	89-	3.5039
2-	.0787	24-	.9449	46-	1.8110	68-	2.6772	90-	3.5433
3-	.1181	25-	.9843	47-	1.8504	69-	2.7165	91-	3.5827
4-	.1575	26-	1.0236	48-	1.8898	70-	2.7559	92-	3.6220
5-	.1969	27-	1.0630	49-	1.9291	71-	2.7953	93-	3.6614
6-	.2362	28-	1.1024	50-	1.9685	72-	2.8346	94-	3.7008
7-	.2756	29-	1.1417	51-	2.0079	73-	2.8740	95-	3.7402
8-	.3150	30-	1.1811	52-	2.0472	74-	2.9134	96-	3.7795
9-	.3543	31-	1.2205	53-	2.0866	75-	2.9528	97-	3.8189
10-	.3937	32-	1.2598	54-	2.1260	76-	2.9921	98-	3.8583
11-	.4331	33-	1.2992	55-	2.1654	77-	3.0315	99-	3.8976
12-	.4724	34-	1.3386	56-	2.2047	78-	3.0709	100-	3.9370
13-	.5118	35-	1.3780	57-	2.2441	79-	3.1102		

### Conversion Factors

TO OBTAIN:	MULTIPLY KNOWN VALUE:	BY:
Atmospheres	In. HG @ 32°F	0.033421
Btu	Watt-hours	3.412
Btu	kwh	3412.
Centimeters	Inches	2.540
cm of Hg @ 0° C	Atmospheres	76.0
cm of Hg @ 0° C	Grams/sq. cm	0.07356
cm of Hg @ 0° C	Lb./sq. in.	5.1715
cm of Hg @ 0° C	Lb./sq. ft.	0.035913
cm/(sec.)(sec.)	Gravity	980.621
Centipoises	Centistokes	Density
Centistokes	Centipoises	1/density
Cu. cm	Cu. ft.	28,317
Cu. cm	Cu. in.	16,387
Cu. cm	Gal. (USA, liq.)	3785.41
Cu. cm	Liters	1000.03
Cu. cm	Quarts (USA, liq.)	946.353
Cu. cm/sec.	Cu. ft./min.	472.0
Cu. ft.	Cu. meters	35.314
Cu. ft.	Gal. (USA, liq.)	0.13368
Cu. ft.	Liters	0.03532
Cu. ft./min.	Cu. meters/sec.	2118.9
Cu. ft./min.	Gal. (USA, liq.)/sec.	8.0192
Cu. ft./sec.	Gal. (USA, liq.)/mir.	0.0022280
Cu. ft./sec.	Liters/min.	0.0005886
Cu. in.	Cu. centimeters	0.061023
Cu. in.	Gal. (USA, liq.)	231.0
Cu. in.	Liters	61.03
Cu. meters	Gal. (USA, liq.)	0.0037854
Cu. meters	Liters	0.001000028
Cu. meters/hr.	Gal./min.	0.22712
Cu. meters/kg	Cu. ft./lb.	0.062428
Cu. meters/min.	Cu. ft./min.	0.02832
Cu. meters/sec.	Gal./min.	0.000063088
Feet	Meters	3.821
Ft./min.	Cm/sec.	1.9685
Ft./sec.	Meters/sec.	3.2808
Ft./sec.)(sec.)	Gravity (sea level)	32.174
Ft./sec.)(sec.)	Meters/(sec.)(sec.)	3.2808
Gal. (Imperial, liq.)	Gal. (USA, liq.)	0.83268
Gal. (USA, liq.)	Barrels (Petroleum, USA)	42
Gal. (USA, liq.)	Cu. ft.	7.4805
Gal. (USA, liq.)	Cu. meters	284.173
Gal. (USA, liq.)	Cu. yards	201.97
Gal. (USA, liq.)	Gal. (Imperial, liq.)	1.2010
Gal. (USA, liq.)	Liters	0.2642
Gal. (USA, liq.)/min.	Cu. ft./sec.	448.83
Gal. (USA, liq.)/min.	Cu. meters/hr.	4.4029
Gal. (USA, liq.)/sec.	Liters/min.	0.0044028
Grams	Pounds (avoir.)	453.5924
Grams/(cm)(sec.)	Centipoises	0.01

TO OBTAIN:	MULTIPLY KNOWN VALUE:	BY:
Grams/cu. cm	Lb./cu. ft.	0.016018
Grams/cu. cm	Lb./cu. in.	27.680
Grams/cu. cm	Lb./gal.	0.119826
Inches	Centimeters	0.3937
Inches of Hg @ 32° F	Atmospheres	29.921
Inches of Hg @ 32° F	Lb./sq. in.	2.0360
Inches of Hg @ 32° F	In. of H <sub>2</sub> O @ 4 C	0.07355
Inches° F	Cm/deg C	0.21872
Kg	Pounds (avoir.)	0.45359
Kg-cal./sq. meter	Btu/sq. ft.	2.712
Kg/cu. meter	Lb./cu. ft.	16.018
Kg/(hr.)(meter)	Centipoises	3.60
Kg/liter	Lb./gal. (USA, liq.)	0.11983
Kg/meter	Lb./ft.	1.488
Kg/sq. cm	Lb./sq. in.	0.0703
Kg/sq. meter	Lb./sq. ft.	4.8824
Kwh	Btu	.0002930
Kwh	Watt-hours	1000.
Liters	Cu. ft.	28.316
Liters	Cu. in.	0.01639
Liters	Cu. meters	999.973
Liters	Gal. (Imperial, liq.)	4.546
Liters	Gal. (USA, liq.)	3.78533
Liters/kg	Cu. ft./lb.	62.42621
Liters/min.	Cu. ft./sec.	1699.3
Liters/min.	Gal. (USA, liq.)/min.	3.785
Liters/sec.	Cu. ft./min.	0.47193
Liters/sec.	Gal./min.	0.063088
Meters	Feet	0.3048
Meters/sec.	Ft./sec.	0.3048
Meters/(sec.)(sec.)	Ft./sec.)(sec.)	0.3048
Ounces	Grams	0.035274
Pounds (avoir.)	Kg	2.2046
Pounds/cu. ft.	Grams/cu. cm	62.428
Pounds/cu. ft.	Pounds/gal.	7.48
Pounds/cu. in.	Grams/cu. cm	0.036127
Pounds/(hr.)(ft.)	Centipoises	2.42
Pounds/inch	Grams/cm	0.0056
Pounds/(sec.)(ft.)	Centipoises	0.00672
Pounds/gal. (USA, liq.)	Kg/liter	8.3452
Pounds/gal. (USA, liq.)	Pounds/cu. ft.	0.1337
Pounds/gal. (USA, liq.)	Pounds/cu. in.	231
Sq. centimeters	Sq. ft.	929.0
Sq. centimeters	Sq. in.	6.4516
Sq. ft.	Sq. meters	10.764
Sq. in.	Sq. centimeters	0.155
Sq. meters	Sq. ft.	0.0929
W-hr.	Btu	.2930
W-hr.	Kwh	.001

### Commonly Used Conversions

1 Cu. Ft. = 1728 Cu. In. = .03704 Cu. Yd. = 7.481 Gal.  
 231 Cu. In. = 1 Gal. = .1337 Cu. Ft.  
 1 Gal. Water = 8.3 Lb.  
 3412 Btu = 1 kwh = 1.34 Hp Hour  
 1 Hp = 745.2 Watts  
 1 Btu = .293 Watt-Hours  
 1 kwh will raise 22.75 Lb. of Water from 62°F to 212°F.  
 1 kwh will Evaporate 3.5 Lb. of Water at 212°F.  
 1 in. = 2.54 cm                      1 sq. in. = 6.452 cm<sup>2</sup>  
 1 ft. = .3048 m                      1 sq. ft. = .0929 m<sup>2</sup>  
 1 yd. = .9144 m  
 1 m = 39.37 in.                      1 kg. = 2.205 lb.  
 1 cu. in. = 16.39 cm<sup>3</sup>  
 1 cu. ft. = .02832 m<sup>3</sup>  
 1 cu. ft. = 28.32 litres  
 1 U.S. Gal. = 3.785 litres

### Prefixes

MEGA = 1,000,000                      DECI = .1  
 KILO = 1,000                              CENTI = .01  
 HECTO = 100                              MILLI = .001  
 DECA = 10                                  MICRO = .000,001

### Temperature Conversions

°F (Fahrenheit) = (°C) + 32                      K (Kelvin) = °C + 273  
 °C (Celcius) =  $\frac{5}{9}$ (°F - 32)                      °R (Rankine) = °F + 460

°C	Temp.	°F	°C	Temp.	°F	°C	Temp.	°F
-17.8	0	32.0	371.1	700	1292.0	760.0	1400	2552.0
10.8	50	122.0	398.9	750	1382.0	787.8	1450	2642.0
37.8	100	212.0	426.7	800	1472.0	815.6	1500	2732.0
65.6	150	302.0	454.4	850	1562.0	843.3	1550	2822.0
93.3	200	392.0	482.2	900	1652.0	872.1	1700	2912.0
121.0	250	482.0	510.0	950	1742.0	899.9	1650	3002.0
148.9	300	572.0	537.8	1000	1832.0	927.7	1600	3092.0
176.7	350	662.0	565.6	1050	1922.0	955.4	1750	3182.0
204.4	400	752.0	593.3	1100	2012.0	983.2	1800	3272.0
232.2	450	842.0	621.1	1150	2102.0	1011.0	1850	3362.0
260.0	500	932.0	648.9	1200	2192.0	1038.8	1900	3452.0
287.8	550	1022.0	676.7	1250	2282.0	1066.6	1950	3542.0
315.6	600	1112.0	704.4	1300	2372.0	1094.3	2000	3632.0
343.3	650	1202.0	732.2	1350	2462.0			

### Interpolation Factors

deg.C	deg.F	deg.C	deg.C	deg.C	
0.58	1	1.8	3.33	6	10.8
1.11	2	3.6	3.89	7	12.6
1.67	3	5.4	4.44	8	14.4
2.22	4	7.2	5.00	9	16.2
2.78	5	9.0	5.56	10	18.0

### fps and cfm Conversions

fps =  $\frac{\text{cfm}}{W \times L \text{ (in feet of duct opening)} \times 60}$   
 cfm = W x L (in feet of duct opening) x 60 x fps

# FORMULAS FOR DETERMINING GEOMETRIC AREAS AND VOLUMES

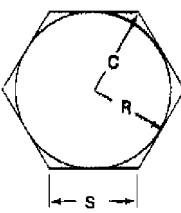
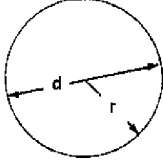
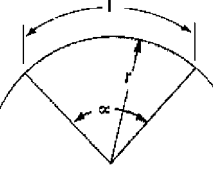
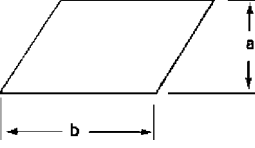
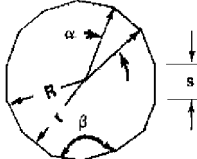
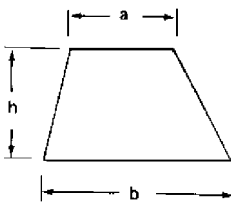
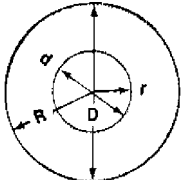
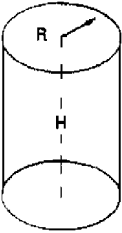
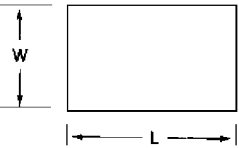
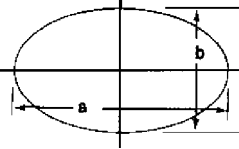
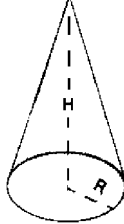
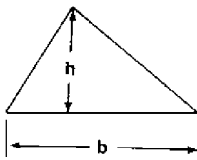
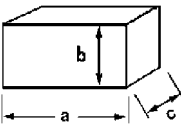
		<p><b>Hexagon</b></p> <p><math>C = S = 1.155R</math>  <math>\text{Area} = 2.598S^2</math>  <math>= 3.464R^2</math></p>
		<p><b>Circle</b></p> <p><math>A = \text{area}</math> <math>C = \text{circumference.}</math>  <math>A = \pi r^2 = \frac{\pi d^2}{4}</math>  <math>C = 2\pi r = \pi D</math></p>
		<p><b>Circular Sector</b></p> <p><math>A = \text{area}</math>; <math>l = \text{length of arc}</math>;  <math>\alpha = \text{angle, in degrees.}</math>  <math>l = \frac{r \times \alpha \times 3.1416}{180}</math>  <math>A = \frac{1}{2} rl</math>  <math>\alpha = \frac{57.296 l}{r}</math></p>
		<p><b>Parallelogram</b></p> <p><math>A = \text{area.}</math>  <math>A = ab</math></p> <p>Note that dimension <math>a</math> is measured at right angles to line <math>b</math>.</p>
		<p><b>Regular Polygon</b></p> <p><math>A = \text{area}</math> <math>n = \text{number of sides.}</math>  <math>\alpha = 360^\circ \div n</math> <math>\beta = 180^\circ - \alpha</math>  <math>A = \frac{nsr}{2} = \frac{ns}{2} \sqrt{\frac{R^2 - s^2}{4}}</math>  <math>R = \sqrt{r^2 + \frac{s^2}{4}}</math>; <math>r = \sqrt{R^2 - \frac{s^2}{4}}</math>;  <math>s = 2\sqrt{R^2 - r^2}</math></p>
		<p><b>Trapezoid</b></p> <p><math>A = \text{area.}</math>  <math>A = \frac{(a + b)h}{2}</math></p>
		<p><b>Circular Ring</b></p> <p><math>A = \text{area}</math>  <math>A = \pi (R^2 - r^2)</math>  <math>= 0.7854 (D^2 - d^2)</math></p>
		<p><b>Cylinder</b></p> <p><math>\text{Area} = 2\pi R (R + H)</math>  <math>\text{Volume} = \pi R^2 H</math></p>
		<p><b>Rectangle or Square</b></p> <p><math>\text{Area} = L \times W</math></p>
		<p><b>Ellipse</b></p> <p><math>a = \text{major axis}</math>; <math>b = \text{minor axis.}</math>  <math>A = \frac{\pi ab}{4}</math></p>
		<p><b>Cone</b></p> <p><math>\text{Area} = \pi R \sqrt{(R^2 + H^2)}</math>  <math>\text{Volume} = \frac{\pi R^2 H}{3}</math></p>
		<p><b>Triangle</b></p> <p><math>A = \text{area.}</math>  <math>A = \frac{bh}{2}</math></p>
		<p><b>Square Prism</b></p> <p><math>V = \text{volume.}</math>  <math>A = \text{area of surface.}</math>  <math>V = abc</math>  <math>A = 2ab + 2ac + 2bc</math></p>

# THERMAL SYSTEM GLOSSARY

**Absolute Zero**—The lowest theoretical temperature. At absolute zero, a body would have no molecular motion or heat energy. Absolute zero is the zero point on the Rankine and Kelvin scale. (-273.15°C or -459.67°F)

**AC**—Alternating Current; an electric current that reverses direction at regularly occurring intervals.

## Accuracy

Calibration Accuracy—the potential error of a device compared to a physical constant or agency standard.

Control Accuracy—maintaining a process at the desired setting. The errors or combination of errors in the entire system including the sensor, control, power, load and design inefficiencies affect control accuracy.

Display Accuracy—the amount of potential error between a measured value and the control's displayed value.

Set Point Accuracy—the potential error between a measured value and the control setting

**Alarm**—a control condition or function, indicating that the process is a predetermined amount above or below the set point.

**Ambient Compensation**—the ability of an instrument to compensate for changes in the ambient temperature so that the changes do not affect control accuracy.

**Ambient Temperature**—the temperature of the immediate surroundings in which equipment is to operate.

**Ampere (amp)**—the rate of flow of current in a circuit.

**Analogue Indication**—a meter with graduated scale and a pointer that moves to indicate process condition.

**Analogue Output**—a voltage or current signal that is a continuous function of the measure parameter.

**Analogue Set Point**—potentiometer adjustment of the control setting

**Anneal**—To relieve stress in a metal or glass material by heating to just below its melting point, then gradually cooling to ambient temperature. Annealing lowers tensile strength while increasing flexibility. Tubular heaters are annealed prior to forming.

**ANSI**—American National Standards Institute

**Anti-reset Windup**—a feature in 3 mode (PID) controls which prevents the integral (automatic reset) circuit from functioning when the temperature is outside the proportional band.

**ASME**—American Society of Mechanical Engineers.

**ASTM**—American Society for Testing and Materials.

**Atmospheric Pressure (Standard)**—Pressure exerted by the earth's atmosphere on the objects within. Measured at 60°F (15°C), at sea level, standard atmospheric pressure is 14.7 psia.

**Automatic Reset (Integral)**—the integral function of a control that automatically compensates for the difference between the set point and the actual process temperature. A signal moves the proportioning band up or down to correct for the droop or offset error.

**Automatic Tuning (of control parameters)**—a control that calculates the optimum PID parameters with a built-in software algorithm to eliminate manual tuning efforts.

**Auxiliary Output**—additional outputs for control of functions other than the primary control output, such as lights, buzzers, horns or gas purges that are triggered by the control alarm function.

**AWG**—American Wire Gauge.

**Bandwidth**—the total temperature variation measured at some point in the system, normally the process.

**Baud Rate**—In serial communications, the rate of information transfer in bits per second.

**Blackbody**—a theoretical object that radiates the maximum amount of energy at a given temperature and absorbs all energy incident upon it.

**Boiling Point**—the temperature at which a substance in the liquid

state transforms to the gaseous state. Commonly refers to the boiling point of water (100°C or 212°F at sea level).

**Btu**—British Thermal Unit; the amount of thermal energy required to raise one pound of water, 1°F .

**Bumpless Transfer**—The smooth, automatic transition from automatic control (closed loop) to manual control (open Loop). The control output is maintained during the transfer.

**Burst Firing**—a fast cycling control output type (3-32VDC for Ogden products) used in conjunction with a solid state relay.

**Calibration**—the process of adjusting an instrument so that the indication is accurate compared to the actual value.

**cfm**—the volumetric flow rate of a liquid or gas in cubic feet per minute.

**Calorie**—the amount of thermal energy required to raise one gram of water 1°C at 15°C

**Cascade**—Control function where the output of one control loop provides the set point for a second loop, which determines the control action.

**CE**—A mark that designates compliance with European Union (EU) requirements for products sold in Europe

**Celsius**—(Centigrade) a temperature scale with 0°C defined as the ice point and 100°C as the boiling point of water at sea level.

**Chatter**—the rapid cycling of a relay due to too narrow a bandwidth in the control.

**Closed Loop Control**—a control system in which process temperature changes are detected by a sensor. The feedback from the sensor allows the control to make adjustments for accurate system regulation.

**Cold Junction Compensation**—a temperature sensitive device that prevents changes in the ambient temperature from affecting the cold junction of a thermocouple.

**Common Mode Line Filter**—a device to filter noise signals on both power lines with respect to ground.

**Common Mode Rejection Ratio**—the ability of an instrument to reject interference from a common voltage at the input terminals with relation to ground. Expressed in dB (decibels).

**Conduction**—the transfer of heat from one material at a given temperature to another material at a lower temperature while in direct contact with each other.

**Continuity Check**—A test that determines whether current flows throughout the length of a circuit.

**Control Loop**—the basic control loop of any automatic control system consists of:

- 1) variable (process)
- 2) sensor
- 3) error detector (of control)
- 4) control
- 5) final control element (relay, SSR, SCR)
- 6) temperature indication

**Control Mode**—the method in which the control restores the system temperature to set point. On/Off, proportioning, and PID are the most common control modes.

**Convection**—the transfer of heat from a source or higher temperature area in a gas or liquid by the movement and mixing of the masses.

**CPS**—Cycles per Second (See Hertz).

**Current Proportioning**— a 4-20 milliamp (typical) current output which provides a current proportional to the amount of control required.

**Cycle Rate**—in a time proportioning control, the period (usually in seconds) of time that is required to complete one on/off cycle once temperature has settled at the center of the proportioning band.

**DC**—direct current; an electric current flowing in one direction and constant in value.

**Data Logging**—Recording a process variable over an extended period of time.

**Dead Band**—the temperature band where no heating or cooling takes place, expressed in degrees.

**Default Parameters**—The programming instructions permanently written in microprocessor software.

**Density**—mass per unit of volume, such as lbs./cu.ft.

**Derivative**—(See Rate)

**Deviation**—the difference between the selected value and the actual value.

**Deviation Alarm**—an offset value that follows the set point. If the set point is 300°F and the Deviation Alarm value is +20°F (or 320°F), then the set point is changed to 350°F, the Deviation Value alarm would be 350°F plus 20°F (or 370°F). See Process Alarm.

**Deviation Meter**—the display of process temperature on meter that indicates temperature relative to the set point.

**Dielectric**—an electrical insulator - a material with low electrical conductivity.

**Dielectric Strength**—an amount of voltage that an insulating material can withstand before an electrical breakdown occurs.

**Differential**—in an on/off control, the temperature difference expressed in degrees between where the control switches off and the control switches on.

**Differential Mode Line Filter**—a device to filter noise signals between two power lines.

**Digital Indication**—the actual process temperature is indicated by LED.

**Digital Set Point**—the desired temperature value is set by means of a pushbutton or pushwheel switch.

**DIN**—Deutsche Industrial Norms, a German agency that sets engineering standards.

**Diode**—Device that allows current to flow in only one direction.

**Drift**—a change in a value over a long period due to changes in factors such as ambient temperature, time or line voltage.

**Droop**—in time proportioning controls, the difference in temperature between the set point and where the system temperature stabilizes. Corrected by automatic or manual reset.

**Dual Output**—the primary output will regulate the process temperature. A secondary output will be utilized for process cooling or as an alarm.

**Duty Cycle**—the time to complete one ON/OFF cycle.

**Efficiency**—the amount of useful output versus energy input.

**Electromagnetic Interference (EMI)**—electrical and magnetic “noise” than can be generated when switching AC power. EMI can interfere with the operation of microprocessor based controls.

**Emissivity**—The ratio of radiant energy emitted from a surface compared to the radiant energy emitted from a black body at the same temperature.

**Endothermic**—a process is endothermic when it absorbs heat.

**Enthalpy**—the sum of the internal energy of a body and the product of its volume multiplied by the pressure used to evaluate the energy change occurring when a vapor or gas is heated. Expressed in units of Btu/lb. or Joules/gram.

**Error**—the difference between the correct value and the reading or display value.

**Exothermic**—a process is exothermic when it generates heat.

**Event**—a programmable On/Off output used to signal peripheral equipment or a process.

**Flow Rate**—speed or velocity of fluid movement.

**Form A Relay**—Single pole, single throw relay with Normally Open (NO) and common contacts. When heat is required for a process, the contacts will close.

**Form B Relay**—Single pole, single throw relay with Normally Closed (NC) and common contacts. Contacts are open when coil is ener-

**Form C Relay**—Single pole, double throw relay with Normally Open (NO), Normally Closed (NC) and common contacts. Can be selected as Form A or Form B contact.

**fpm**—flow velocity in feet per minute.

**fps**—flow velocity in feet per second.

**Fahrenheit**—a temperature scale with 32°F defined as the ice point and 212°F as the boiling point of water at sea level.

**Frequency**—the number of event occurrences or cycles over a specified period of time.

**Freezing Point**—the temperature where a material changes from a liquid to a solid.

**Fuse**—A device that interrupts power in a circuit when an overload occurs.

**Fuzzy Logic**—An artificial intelligence technique that allows control decisions to be made upon approximate or incomplete information. Fuzzy Logic is a continuous decision making function that can prevent initial overshoot and set point differentials.

**GIGA**—the prefix for one billion (G).

**gph**—the volumetric flow rate in gallons per hour.

**gpm**—the volumetric flow rate in gallons per minute.

**Ground**—the electrical neutral line having the same potential as the surrounding earth; the negative side of a DC power supply; the reference point for an electrical system.

**Grounded Junction**—A thermocouple junction in which the sheath and conductors are welded together forming a completely sealed integrated junction.

**Heat**—thermal energy expressed in Calories, Btu's or Joules.

**Heat Balance**—proper sizing of the heat source to the requirements of the system (including heat losses) (See: “Calculating Heating Requirements” in the Engineering Section).

**Heat of Fusion**—the amount of energy required to change one pound of a material from a solid to a liquid without an increase in temperature. Expressed in Btu/lb.

**Heat of Vaporization**—the amount of energy required to change one pound of a material from a liquid to a vapor without an increase in temperature. Expressed in Btu/lb.

**Heat Sink**—heat conducting material used to dissipate heat.

**Heat Transfer**—a process of thermal energy flowing from one body to another.

1) Conduction: the transfer of heat from one particle of matter to another.

2) Convection: the transfer of heat from one part of a particle to another by the mixing of the warmer particles with the cooler.

3) Radiant: the transfer of heat from one body to another as the result of the bodies emitting and absorbing radiation energy.

**Heat Transfer Medium**—a gas, liquid or solid through which heat flows from the heat source to the work.

**Hertz**—units of expression for frequency, measured in cycles per second.

**Hi-Pot Test**—to apply a high voltage to an electrical conductor to test the surrounding insulation.

**Hysteresis**—the temperature sensitivity designed into the on/off control action between the on and off switching points. Expressed in percentage of control range.

**Ice Point**—the temperature where pure water freezes (0°C or 32°F).

**Impedance**—the total opposition in a circuit to the flow of alternating current. Measured in ohms and represented by “Z”.

**Infrared**—or radiation is the exchange of energy by electromagnetic waves. The infrared spectrum extends from the deep red end of the visible spectrum to the microwave region of the radio spectrum, The portion adjacent to the visible spectrum is of importance to heating. Radiant heat transfer can be very efficient in directing energy from the heat source to an object.

**Isolation**—Electrical Separation

**Isothermal**—a process or area that maintains a constant temperature.

**Integral**—(See Automatic Reset).

**Joule**—the basic unit of thermal energy. 1 Joule equals 1 ampere passed through a resistance of 1 ohm for 1 second.

**Junction**—A thermocouple junction is the point at which two alloys are joined. A typical thermocouple circuit would have a measuring and a reference junction.

**Kelvin**—the unit of absolute or thermodynamic temperature scale. Zero Kelvin is absolute zero, where all molecular activity stops. No ° symbol is used. 0°C = 273.15K; 100°C = 373.15K.

**Kilo**—the prefix for one thousand (K).

**Kilowatt (kw)**—1000 watts or 3412 Btu per hour.

**Kilowatt Hour**—electrical unit of energy expended by one kilowatt in one hour.

**Least Significant Digit**—The digit farthest to the right in a display.

**Linearity**—the deviation of an instrument's response from a straight line.

**Load**—the electrical demand of a process expressed as wattage, amps or resistance (ohms).

**Manual Reset**—the adjustment on a proportional control which shifts the proportioning band in relation to the set point to eliminate droop of offset errors.

**Mass Flow Rate**—weight of a substance flowing per unit of time past a specific cross-sectional area within a system.

**Mean Temperature**—the maximum and minimum temperature average of a process at equilibrium.

**Measuring Junction**—the thermocouple junction at the point of measurement in the process.

**Mega**—the prefix for one million (M) (10<sup>6</sup>).

**Mechanical Relay**—an electromechanical device that completes or breaks a circuit by opening or closing electrical contacts.

**Micro**—The prefix for one millionth (10<sup>-6</sup>).

**Microamp**—10<sup>-6</sup> amps (one millionth of an amp).

**Micron**—10<sup>-6</sup> meters (one millionth of a meter).

**Milli**—The prefix for one thousandth (10<sup>-3</sup>).

**Microprocessor**—The central processing unit (CPU) that performs the logic operations in a micro-computer system. The microprocessor in a process or instrument control decodes instructions from the stored program, performs algorithmic and logic functions, and produces signals and commands.

**Milliamp**—10<sup>-3</sup> amps (one thousandth of an amp).

**Millivolt**—10<sup>-3</sup> volts (one thousandth of a volt).

**NEC**—National Electrical Code

**NEMA**—National Electrical Manufacturer's Association

**Noise**—undesirable electrical interference on the signal wires.

**Noise Suppression**—a device used to reduce electrical interference.

**Normal Mode Rejection Ratio**—the ability of an instrument to reject interference of the line frequency (50-60Hz) across the input terminals.

**NPT**—National Pipe Thread

**Offset**—the difference in temperature between the set point and the actual process temperature.

**OHM**—The unit of electric resistance.

**On-Off**—a control whose action is full on or full off.

**Open Loop Control**—a control system with no sensing feedback.

**Overshoot**—excursion of temperature above the set point.

**Phase**—time based relationship between an intermittent function and a reference. Electrically, the expression is in angular degrees to describe the voltage or current relationship of two alternating waveforms.

**Phase Proportioning**—a temperature control form where the power supplied to the process is controlled by limiting the phase angle of the line voltage.

**PID**—three mode temperature control—proportional, integral (automatic reset), derivative (rate).

**Polarity**—having two oppositely charged poles; one positive, one negative.

**Potting**—The sealing of components with a compound such as epoxy

to protect against moisture and other contaminants.

**Process Alarm**—a fixed alarm or secondary set point value independent of the primary set point. Should a process value exceed this value, an alarm condition would register.

**Process Variable**—the parameter being controlled or measured such as temperature, relative humidity, flow, level, pressure, etc.

**Proportioning Band**—a temperature band in degrees within which a control's proportioning function is active.

**Proportioning Control Mode**—when process temperature approaches set point and enters the proportioning band, the output is switched on and off at the established cycle time. The change in power to the load provides a throttling action which results in less temperature overshoot. This cycling will continue until on and off times are equal.

**psia**—pounds per square inch absolute. Pressure reference to a vacuum.

**psig**—pound per square inch gage. Pressure reference to ambient air pressure.

**Quality of Steam**—the relative amount of liquid present in saturated steam as a percent of the total weight. The quality of steam is 100% less the percent liquid. Dry saturated steam has a quality of 100%.

**Ramp**—a programmed rise in temperature.

**Range**—an area between two limits in which a measurement or control action takes place. Typically expressed in upper and lower limits.

**Rankine**—an absolute temperature scale based upon the Fahrenheit scale with 180° between the ice point and boiling point of water. 0°F = 459.67°R.

**Rate (derivative)**—a control function that measures the rate of increase or decrease of the system temperature and brings the control into an accelerated proportioning action. This mode prevents an overshoot condition at initial heat-up and with system disturbances.

**Rate Time**—the interval over which the system temperature is sampled for the derivative function.

**Repeatability**—the ability to give the same output or measurement under repeated identical conditions.

**Resistance**—the resistance to the flow of electric current measured in ohms.

**Resolution Sensitivity**—the amount of temperature change that must occur before the control will actuate. It may be expressed in temperature or as a percentage of the control's scale.

**Response Time**—In analog instruments, the time required for a change of the measured quantity to change the indication. In sensors, the time required to reach 63.2% of the step change.

**Retransmit Output**—analog output scaled to the process or the set point value.

**RS232 or RS485 Output Signal**—A serial interface suitable for connection between a digital control and a personal computer, a host computer or printer.

**RTD**—a temperature sensing probe of finely wound platinum wire that displays a linear resistance change for a corresponding temperature change. The resistance increases as the temperature rises. A base resistance of 100 ohms at 32°F is the industry (DIN) standard.

**Saturation Temperature**—the boiling temperature of a liquid at the existing pressure.

**SCFM**—Volumetric flow rate in cubic feet per minute at 60°F (15°C) and standard atmospheric pressure.

**SCR**—Silicone Controlled Rectifier

**Sensor Breakdown Protection**—circuitry which ensures safe process shut down in the event of sensor failure.

**Serial Communications**—A method of transmitting data between devices.

**Set Point**—control setting to achieve or maintain temperature.

**Shape Factor**—in radiant applications, the amount of energy received by the target relative to heater rating and distance to the target.

**Shield**—material surrounding a conductor(s) to prevent electrostatic or EMI from external sources.

**Slide Wire Feedback**—A potentiometer that varies the resistance to control a valve position.

**Soak**—To raise the temperature of a metal object in a heated environment to produce a metallurgical change.

**Standard**—a reference point from which references or calibrations are made.

**Soft Start**—reduces voltage on initial start-up which reduces power to the heaters. If heater has accumulated moisture internally during a shut down, soft start will allow heater to dry before full voltage is applied extending heater life.

**Solid State Relay**—a solid state switching device which completes or breaks a circuit electrically with no moving parts.

**Span**—the difference between the upper and lower limits of a controller's range.

**Specific Gravity**—the ratio of mass of any material to the same volume of pure water at 4°C.

**Specific Heat**—the ratio of thermal energy required to raise the temperature of a particle 1 degree to the thermal energy required to raise an equal mass of water 1 degree.

**Speed of Response**—time needed for a temperature change occurring at the sensor to be translated into a control action.

**Stability**—the ability of an instrument or sensor to maintain a constant output when a constant input is applied.

**Standard**—a reference point from which references or calibrations are made.

**Super Heating**—the heating of a liquid above its boiling temperature without changing to a gaseous state; or the heating of a gas considerably above the boiling temperature.

**Surge Current**—a current of short duration occurring when power is initially applied to capacitive or resistive loads, usually lasting no more than several cycles.

**Temperature Gradient**—the range of temperature variations at various physical locations throughout a thermal system.

**Tera**—the prefix for one trillion(T).

**Thermal Conductivity**—the property of a material to conduct heat.

**Thermal Expansion**—an increase in size due to an increase in temperature.

**Thermal Lag**—the time delay in the distribution of heat throughout a thermal system.

**Thermal System**—a series of components arranged and designed to provide heat. The four elements or components comprising a Thermal System are:

- 1) work or load
- 2) heat source
- 3) heat transfer medium
- 4) control system

**Thermistor**—a temperature sensing probe manufactured of a mixture of metal oxides then encapsulated in epoxy or glass. A large change in resistance is exhibited proportional to a change in temperature. The resistance usually decreases as temperature rises.

**Thermocouple**—a temperature sensing probe consisting of the junction of two dissimilar metals which has a millivolt output proportional to the difference in temperature between the "hot" junction and the lead wires (cold junction).

**Thermowell**—a closed-end tube into which a temperature sensor is inserted to isolate it from the environment.

**Transducer**—a device that converts a measured variable into another form which is the transducer's output. A thermocouple transforms heat to a millivolt output.

**Transmitter**—a device used to transmit temperature data from the sensor.

**Undershoot**—excursion of temperature below set point.

**Ungrounded Junction**—A thermocouple junction fully insulated from the sheath.

**Viscosity**—the inherent resistance of a substance to flow

**Voltage**—an electrical potential which is measured in volts.

**Wattage**—a measurement of electrical power. In a resistive circuit,  $VI = W$  (See Ohms Law formulas).

**Watt Density**—the rated wattage of an element per unit of surface area. Usually expressed in watts per square inch.

**Zero Voltage Switching**—completing or breaking of a circuit when the voltage wave form crosses zero voltage.

# COMMON ABBREVIATIONS AND ACRONYMS

<b>AC</b> —alternating current	<b>FFT</b> —fast Fourier transform	<b>OI</b> —operator interface
<b>A/D</b> —analog-to-digital	<b>FIA</b> —flow injection analysis	<b>OOD</b> —object oriented design
<b>AEC</b> —architect, engineer and constructor	<b>FID</b> —flame ionization detector	<b>OOP</b> —object oriented programming
<b>AI</b> —artificial intelligence	<b>FIP</b> —factory information protocol	<b>OSI</b> —open systems interconnection
<b>ANDF</b> —architecture neutral distribution format	<b>FMS</b> —flexible manufacturing system	<b>P&amp;ID</b> —piping and instrumentation diagram
<b>ASCI</b> —application specific integrated circuit	<b>FS</b> —full scale	<b>PB</b> —proportional band
<b>API</b> —application programming interface	<b>FTIR</b> —Fourier transform infrared	<b>PC</b> —personal computer or programmable controller
<b>ATG</b> —automatic tank gauge	<b>GC</b> —gas chromatograph	<b>PD</b> —positive displacement
<b>BCD</b> —binary coded decimal	<b>GPB</b> —general purpose interface bus	<b>PI</b> —pneumatic-to-current
<b>BPS</b> —bits per second	<b>GUI</b> —graphical user interface	<b>PI</b> —proportional-integral
<b>CAD</b> —computer-aided design	<b>HCFC</b> —hydrochlorofluorocarbon	<b>PID</b> —proportional-integral-derivative
<b>CAE</b> —computer-aided engineering	<b>HPLC</b> —high pressure liquid chromatography	<b>PLC</b> —programmable logic controller
<b>CAM</b> —computer-aided manufacturing	<b>HPV</b> —high performance vane	<b>PROM</b> —programmable logic controller
<b>CASE</b> —computer-aided software engineering	<b>HTG</b> —hydrostatic tank gauge	<b>PSA</b> —pressure sensitive adhesive
<b>C/C</b> —center-to-center	<b>IC</b> —integrated circuit	<b>PRV</b> —pressure reducing valve
<b>CFC</b> —chlorofluorocarbon	<b>I/O</b> —input/output	<b>PV</b> —process variable or process value
<b>CIE</b> —computer integrated enterprise	<b>ID</b> —inside diameter	<b>QC</b> —quality control
<b>CIM</b> —computer integrated manufacturing	<b>I/P</b> —current-to-pneumatic	<b>R&amp;D</b> —research and development
<b>CIP</b> —clean in place	<b>IR</b> —infrared	<b>RAM</b> —random access memory
<b>CJC</b> —cold junction compensation	<b>IS</b> —intrinsic safety	<b>RF</b> —radio frequency
<b>CMOS</b> —complementary metal oxide semi-conductor	<b>JIT</b> —just-in-time	<b>RFI</b> —radio frequency interference
<b>CNC</b> —computer numerical control	<b>LAN</b> —local area network	<b>RH</b> —relative humidity
<b>CPU</b> —central processing unit	<b>LC</b> —liquid chromatograph	<b>RMS</b> —root mean square
<b>CRC</b> —cyclic redundancy check	<b>LCD</b> —liquid crystal display	<b>ROM</b> —read-only memory
<b>CRT</b> —cathode ray tube	<b>LCL</b> —lower control unit	<b>RSS</b> —root sum squared
<b>CSA</b> —Canadian Standards Association	<b>LDES</b> —linear discrimination expert system	<b>RTD</b> —resistance temperature detector
<b>CT</b> —current transformer	<b>LED</b> —light emitting diode	<b>RTU</b> —remote terminal unit
<b>D/A</b> —digital-to-analog	<b>LEL</b> —lower explosive limit	<b>RV</b> —relief valve
<b>DAS</b> —data acquisitions system	<b>LIMS</b> —laboratory information management system	<b>SCADA</b> —supervisory control and data acquisition
<b>DC</b> —direct current	<b>LP</b> —linear programming	<b>SCR</b> —silicon controlled rectifier
<b>DCE</b> —distributed computing environment	<b>MACT</b> —maximum achievable control technology	<b>SFC</b> —supercritical fluid chromatography
<b>DCS</b> —distributed control system	<b>MAG</b> —manufacturing automation protocol	<b>SNA</b> —systems networking architecture
<b>DES</b> —discrimination expert system	<b>MGP</b> —magnesium oxide	<b>SP</b> —set point
<b>DIN</b> —Deutsches Institute fur Normung	<b>MIPS</b> —millions instructions per second	<b>SPC</b> —statistical process control
<b>DMA</b> —direct memory access	<b>MIS</b> —management information services	<b>SPDT</b> —single pole, double throw
<b>DNC</b> —direct numerical control	<b>MMI</b> —man machine interface	<b>SQC</b> —statistical quality control
<b>DOS</b> —disk operating system	<b>MMS</b> —manufacturing message system	<b>SSR</b> —solid state relay
<b>DP</b> —differential pressure	<b>MTBF</b> —meantime between failures	<b>SSC</b> —single station controller
<b>DPDT</b> —double pole, double throw	<b>MTTD</b> —mean time to detect	<b>SV</b> —set point value
<b>DPM</b> —digital panel meter	<b>MTTF</b> —mean time to fail	<b>T/C</b> —thermocouple
<b>DRAM</b> —dynamic random access memory	<b>MODEM</b> —modulating/demodulating module	<b>TCD</b> —thermal conductivity detector
<b>EHL</b> —effective heated length	<b>MPCD</b> —manufacturing planning and control software	<b>THD</b> —total harmonic distortion
<b>EMI</b> —electro magnetic interference	<b>MRP</b> —material requirements planning	<b>TOP</b> —technical office protocol
<b>EMS</b> —expanded memory specification	<b>MRP II</b> —manufacturing resource planning	<b>TPM</b> —total predictive maintenance
<b>EPA</b> —enhanced performance architecture	<b>NC</b> —normally closed	<b>TQC</b> —total quality control
<b>EPROM</b> —erasable, programmable read-only memory	<b>NC</b> —numerical control	<b>TVSS</b> —transient voltage surge suppressor
<b>ERP</b> —enterprise resource planning	<b>NDIR</b> —non-dispersive infrared	<b>UCL</b> —upper control limit
<b>ES</b> —expert system	<b>NIR</b> —near infrared	<b>UPS</b> —uninterruptible power supply
<b>EVOP</b> —evolutionary operations	<b>NO</b> —normally open	<b>UV</b> —ultraviolet
<b>EWMA</b> —exponentially weighted moving average	<b>OCR</b> —optical character recognition	<b>VDT</b> —video display terminal
<b>FCS</b> —field control station	<b>OD</b> —outside diameter	<b>VFD</b> —variable frequency drive
	<b>OEM</b> —original equipment manufacturer	<b>VME</b> —virtual memory executive system
		<b>WAN</b> —wide area network
		<b>WIP</b> —work-in-process

**WARRANTY:** OGDEN makes no warranties or representations of any sort regarding the fitness for use, or the application of its products by the Purchaser. The selection, application or use of OGDEN products is the Purchaser's responsibility. OGDEN products are warranted to be free from defects in material and workmanship. OGDEN's sole responsibility under this warranty is to repair or replace, free of charge, F.O.B. its factory, items determined by OGDEN to be defective. The period of the warranty is one year from the manufacturing date, or three years for products so marked. Some additional time is extended for items purchased through and stocked by authorized OGDEN Service Centers. All warranties exist between OGDEN and the first party Purchaser. No claims will be allowed for labor, material, loss of profit or damages in shipping, handling, in installation or by abuse. OGDEN will not honor back charges for any alterations, modifications or revisions of any kind. OGDEN cannot warranty any immersion heater against failure by sheath corrosion if caused by operating conditions beyond the control of OGDEN. The ultimate selection of sheath and other immersion heater component materials are the responsibility of the Purchaser.

**RETURNS:** No products returned can be accepted without a completed Return Material Authorization form.

#### Variance in Quantity (VIQ):

Because of special manufacturing requirements and processes, Ogden may ship the following Variances in Quantity:

<u>Order Quantity</u>	<u>VIQ</u>
1-6 pieces	0
7-24 pieces	± 1
25-49 pieces	± 2
50-80 pieces	± 3
81-99 pieces	± 4
100+	±5%

There is no overshipment on items with a net value over \$125. However, certain items of extraordinary difficulty may exceed above VIQ.

The following are registered trademarks of OGDEN Manufacturing Co.: OGDEN, Mighty-Blade, Golden-Ray, Chameleon, Mighty Watt, Mighty Watt Plus, Mighty Watt Grabber, Bullet, Maxi-Zone, Mighty-Tuff, Mighty-Miser, Aluma-Flex, Mini-Tubular, ETR, Smarter Logic, ETR-9090, ETR-3200, ETR-9200, ETR-3100, ETR-9300. MARCA REGISTRADA